



KONSTANTINIDIS
GROUP OF COMPANIES



Catalogue

Rotary Cultivator 25MEE

Ultra lightweight rotary cultivator, 1 speed, chain drive, 540 P.T.O. For 10-25 H.P. tractors.



TYPE	TRACTOR HORSEPOWER	WORKING WIDTH		TOTAL WIDTH	WEIGHT	NUMBER OF DISCS & BLADES	DEPTH OF WORK
		cm	ins				
MEE 80	10-12	95	37"	105	138	5/20 CURVED	12
MEE 105	12-14	105	41"	155	143	6/20 CURVED	12
MEE 115	13-15	115	45"	125	148	6/24 CURVED	12
MEE 120	14-16	125	50"	130	153	6/24 CURVED	12
MEE 130	15-18	130	51"	140	158	6/24 CURVED	12

- *Cardan shaft included*



Rotary Cultivator 40 ME

Lightweight rotary cultivator, 1 speed, chain drive, 540 P.T.O. For 14-40 H.P. tractors.

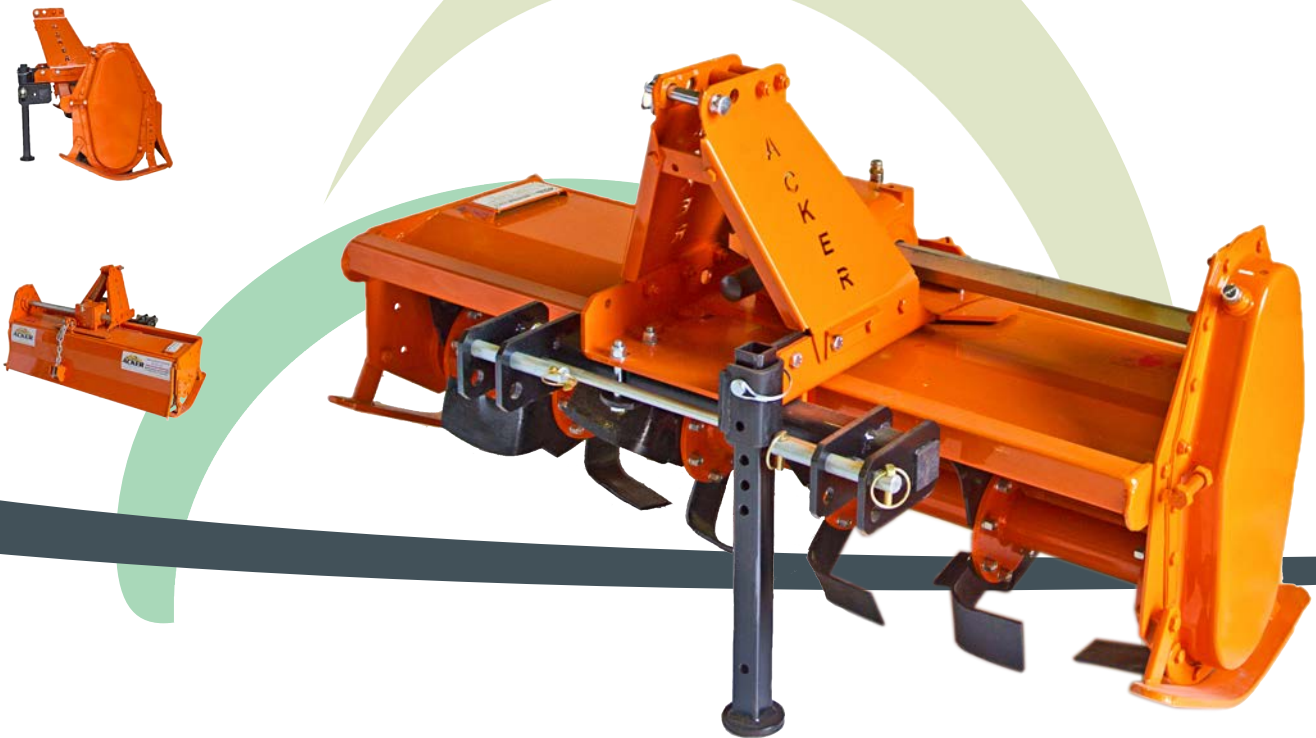

TYPE	TRACTOR HORSEPOWER	WORKING WIDTH		TOTAL WIDTH	WEIGHT	NUMBER OF DISCS & BLADES	DEPTH OF WORK
		cm	ins				
MERL 80	14-16	80	32"	95	180	5/16 CURVED	15
MERL 95	16-20	95	37"	110	195	6/20 CURVED	15
MERG 105	20-25	105	41"	120	210	5/16 ANGLED	15
MERL 115	25-30	115	45"	130	225	7/24 CURVED	15
MERG 125	30-35	125	50"	140	240	6/20 ANGLED	15
MERL 135	35-38	135	53"	150	255	7/28 CURVED	15
MERG 150	35-40	150	60"	165	270	7/24 ANGLED	15

- *Cardan shaft included*

Rotary Cultivator 75 M(N)

Sliding rotary cultivator, medium heavy-weighted, with 4 speeds, gear drive, 540 P.T.O. and hydraulically movable. For tractors up to 25-75 H.P.



TYPE	TRACTOR HORSEPOWER	WORKING WIDTH		TOTAL WIDTH	WEIGHT	NUMBER OF DISCS & BLADES	DEPTH OF WORK
	H.P.	cm	ins	cm	kg		cm
M(N) 130	30-35	130	50"	155	400	6/30 ANGLD	20
M(N) 155	40-45	155	60"	180	460	7/36 ANGLD	20
M(N) 180	45-50	180	70"	205	510	8/42 ANGLD	20

- *Cardan shaft included*
- *Comer gearbox, type MZ-1A*



Rotary Cultivator 75 SK(N)

Fixed, medium heavy-weighted, reinforced rotary cultivator, with 4 speeds, gear drive, 540 P.T.O. For tractors up to 75 H.P.

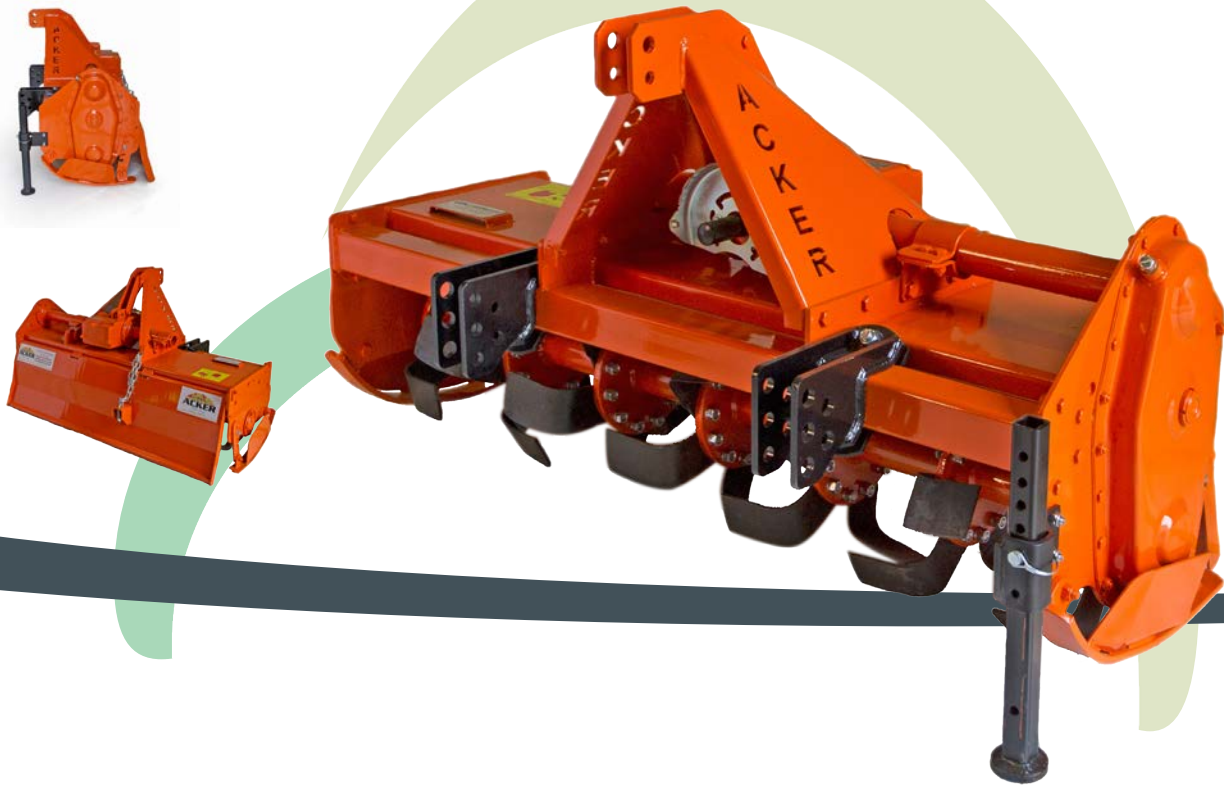

TYPE	TRACTOR HORSEPOWER	WORKING WIDTH		TOTAL WIDTH	WEIGHT	NUMBER OF DISCS & BLADES	DEPTH OF WORK
	H.P.	cm	ins	cm			
SK(N) or SP(N) 105	25-30	105	40"	125	275	5/24 ANGLD	22
SK(N) or SP(N) 130	30-40	130	50"	155	355	6/30 ANGLD	22
SK(N) or SP(N) 155	40-50	155	60"	175	395	7/36 ANGLD	22
SK(N) or SP(N) 180	50-55	180	70"	200	440	8/42 ANGLD	22
SK(N) or SP(N) 205	60-75	205	80"	225	495	9/48 ANGLD	22

- *Cardan shaft included*
- *SK(N) central or SP(N) lateral*



Rotary Cultivator 75 SY(N)

Fixed, medium heavy-weighted, reinforced, hydraulically movable rotary cultivator, with 4 speeds, gear drive, 540 P.T.O. For tractors up to 75 H.P.

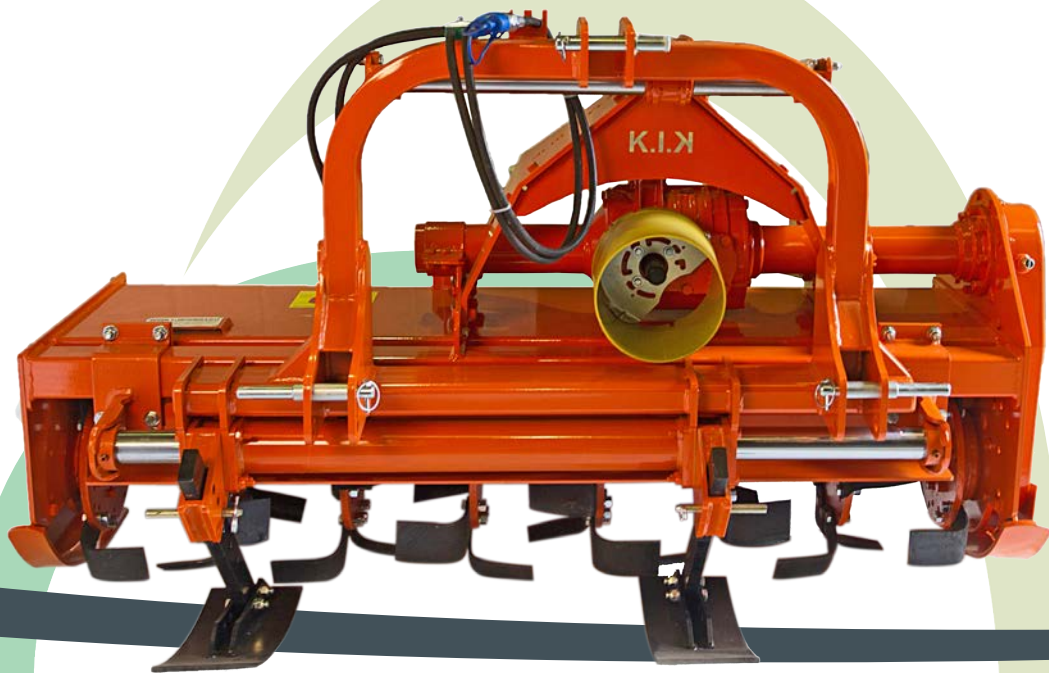

TYPE	TRACTOR HORSEPOWER	WORKING WIDTH		TOTAL WIDTH	WEIGHT	NUMBER OF DISCS & BLADES	DEPTH OF WORK
	H.P.	cm	ins	cm			kg
SY(N) 130	30-40	130	50"	155	400	6/30 ANGLED	22
SY(N) 155	40-50	155	60"	175	400	7/36 ANGLED	22
SY(N) 180	50-55	180	70"	200	500	8/42 ANGLED	22
SY(N) 205	60-75	205	80"	225	550	9-48 ANGLED	22

- *Cardan shaft included*
- *Straight or curved blades available on demand*
- *Comer gearbox, type MZ-1A*



Rotary Cultivator 100 E-ET CHAIN

Fixed, heavy-weighted rotary cultivator, with 4 speeds, chain drive, 540 P.T.O. For tractors up to 100 H.P.

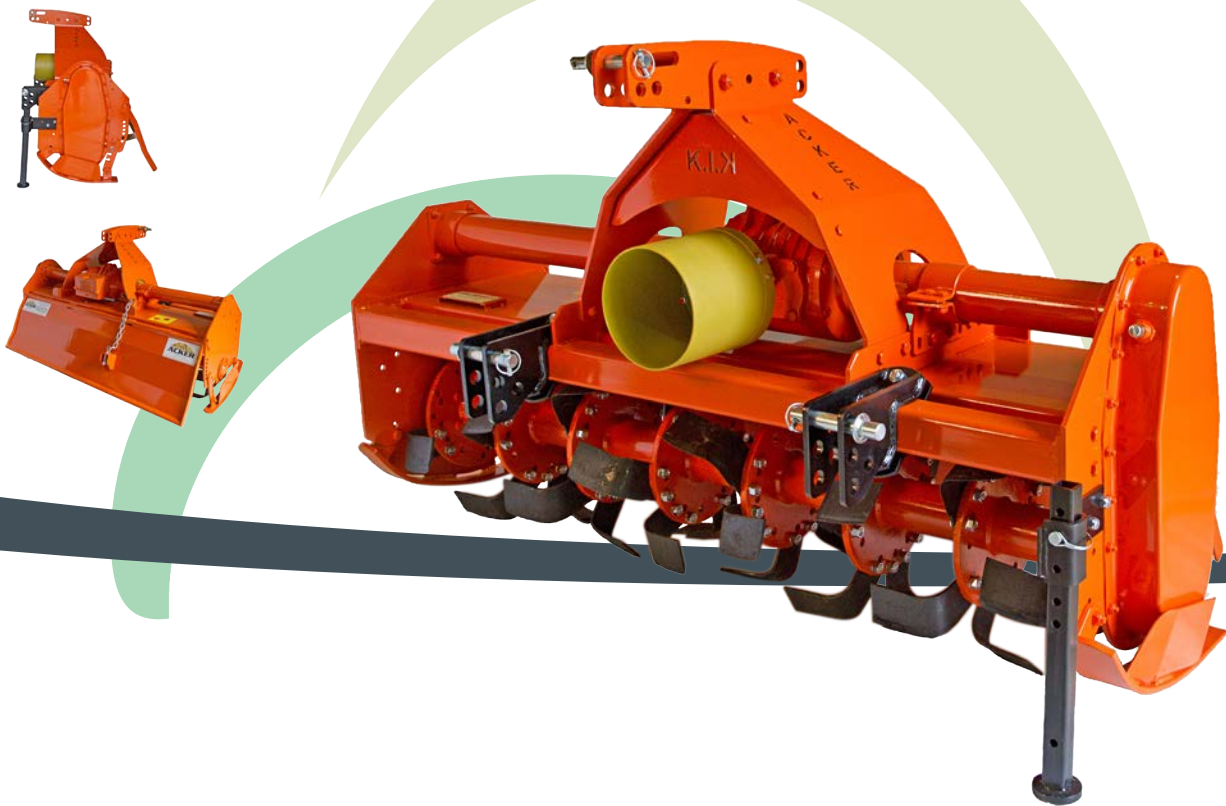

STANDARD EQUIPMENT

- Cardan shaft included
- Blade Axle Rotations: 132, 153, 186, 216 rpm
- Comer gearbox, type MZ-4A

ADDITIONAL EQUIPMENT UPON REQUEST

- Depth wheel
- Extension of reducer's angle

Sindos Industrial Area 4-A7
ZIP Code 57022, Thessaloniki
T: +30 2310 79.79.84 -85
T: +30 2310 79.99.88
F: +30 2310 79.96.27
info@acker.gr
www.acker.gr

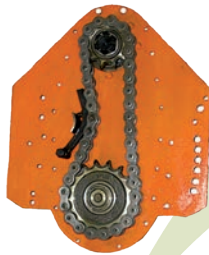

CHAIN DRIVE

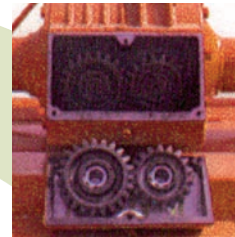

**COMER GEARBOX,
TYPE MZ-4A**

TYPE	TRACTOR HORSEPOWER	WORKING WIDTH		TOTAL WIDTH	WEIGHT	NUMBER OF DISCS & BLADES	DEPTH OF WORK
	H.P.	cm	ins	cm	kg		cm
E 130	50-60	130	50"	155	520	6/30 ANGLED	25
E 155	60-70	155	60"	175	565	7/36 ANGLED	25
E 180	70-80	180	70"	200	600	8/42 ANGLED	25
E 205	80-90	205	80"	230	645	9-48 ANGLED	25
E 230	90-100	230	90"	255	690	10-54 ANGLED	25

Rotary Cultivator 100 E-ET **GEAR**

Fixed, heavy-weighted rotary cultivator,
with 4 speeds, gear drive, 540 P.T.O. For
tractors up to 100 H.P.

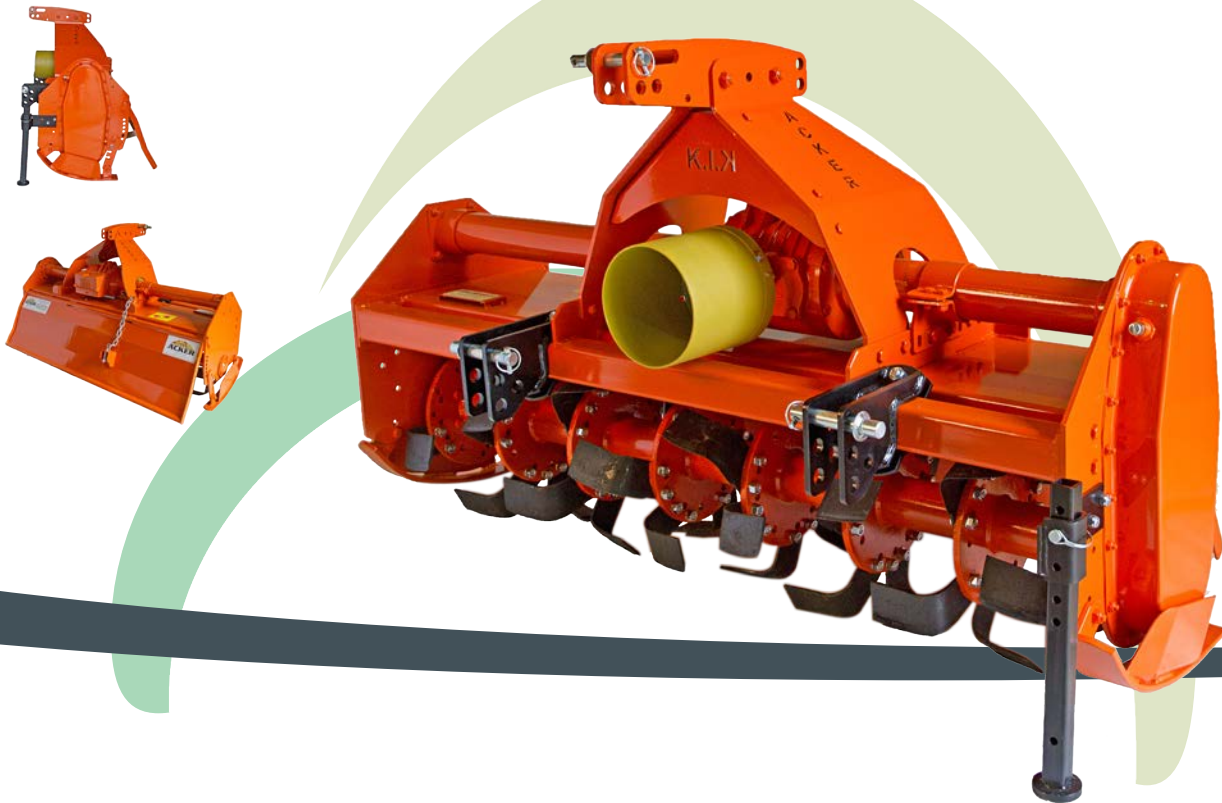

STANDARD EQUIPMENT

- *Cardan shaft included*
- *Blade Axle Rotations: 132, 153, 186, 216 rpm*
- *Comer gearbox, type MZ-4A*
- *Central E or Lateral EP*

ADDITIONAL EQUIPMENT UPON REQUEST

- *Depth wheel*

Rotary Cultivator 100 E-ET **GEAR**

Sindos Industrial Area 4-A7
 ZIP Code 57022, Thessaloniki
 T: +30 2310 79.79.84 -85
 T: +30 2310 79.99.88
 F: +30 2310 79.96.27
 info@acker.gr
 www.acker.gr



GEAR DRIVE

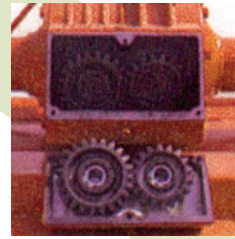

**COMER GEARBOX,
TYPE MZ-4A**

TYPE	TRACTOR HORSEPOWER	WORKING WIDTH		TOTAL WIDTH	WEIGHT	NUMBER OF DISCS & BLADES	DEPTH OF WORK
	H.P.	cm	ins	cm	kg		cm
E 130	50-60	130	50"	155	520	6/30 ANGLED	25
E 155	60-70	155	60"	180	565	7/36 ANGLED	25
E 180	70-80	180	70"	205	600	8/42 ANGLED	25
E 205	80-90	205	80"	230	645	9-48 ANGLED	25
E 230	90-100	230	90"	255	690	10-54 ANGLED	25

Rotary Cultivator 100EU

Fixed, heavy-weighted rotary cultivator, hydraulically movable, with 4 speeds, gear drive, 540 P.T.O. For tractors up to 100 H.P.

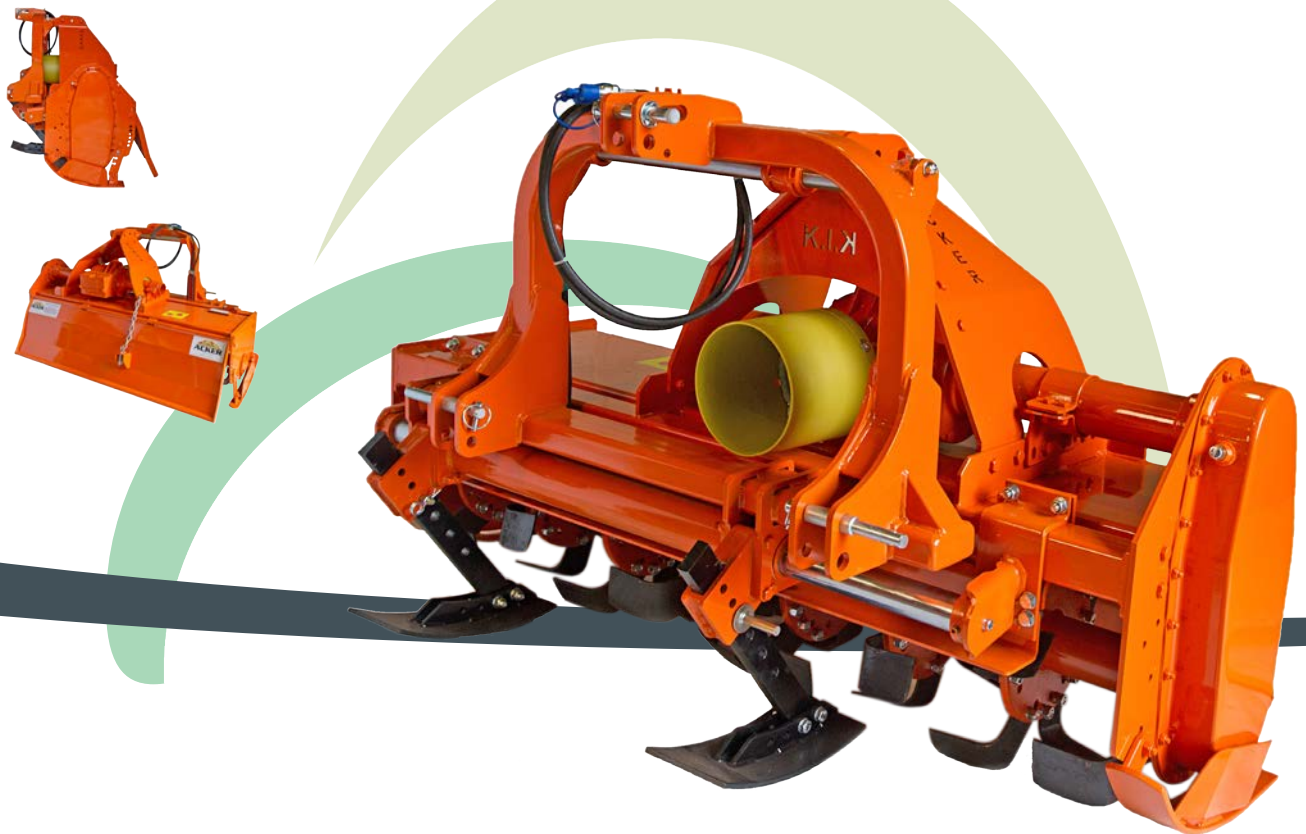

STANDARD EQUIPMENT

- Cardan shaft included
- Blade Axle Rotations: 132, 153, 186, 216 rpm
- Comer gearbox, type MZ-4A
- Central E or Lateral EP



Rotary Cultivator 100EU

Sindos Industrial Area 4-A7
 ZIP Code 57022, Thessaloniki
 T: +30 2310 79.79.84 -85
 T: +30 2310 79.99.88
 F: +30 2310 79.96.27
 info@acker.gr
 www.acker.gr



GEAR DRIVE

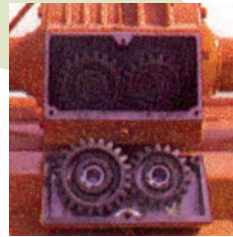

**COMER GEARBOX
 TYPE MZ-4A**

TYPE	TRACTOR HORSEPOWER	WORKING WIDTH		TOTAL WIDTH	WEIGHT	NUMBER OF DISCS & BLADES	DEPTH OF WORK
	H.P.	cm	ins	cm	kg		cm
EU 130	50-60	130	50"	155	620	6/30 ANGLD	25
EU 155	60-70	155	60"	180	665	7/36 ANGLD	25
EU 180	70-80	180	70"	205	700	8/42 ANGLD	25
EU 205	80-90	205	80"	230	745	9-48 ANGLD	25
EU 230	90-100	230	90"	255	790	10-54 ANGLD	25

Rotary Cultivator 130 EY/EYT **CHAIN**

Fixed, super heavy-weighted rotary cultivator, with 4 speeds, chain drive, 540 or 1000 P.T.O. For tractors up to 130 H.P.



STANDARD EQUIPMENT

- *Cardan shaft included*
- *Comer gearbox, type MZ-3A*



Sindos Industrial Area 4-A7
ZIP Code 57022, Thessaloniki
T: +30 2310 79.79.84 -85
T: +30 2310 79.99.88
F: +30 2310 79.96.27
info@acker.gr
www.acker.gr

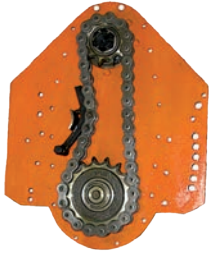

CHAIN DRIVE

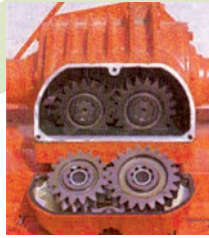

**COMER GEARBOX,
TYPE MZ-3A**

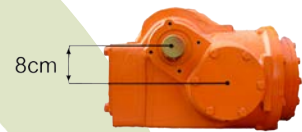

**COMER GEARBOX,
TYPE MZ-815**

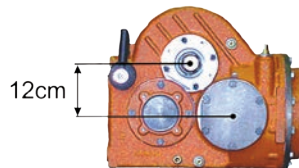

**COMER GEARBOX,
TYPE DZ-733**

TYPE	TRACTOR HORSEPOWER	WORKING WIDTH		TOTAL WIDTH	WEIGHT	NUMBER OF DISCS & BLADES	DEPTH OF WORK
	H.P.	cm	ins	cm	kg		cm
EY 180	70-90	180	70"	205	635	8/42 ANGLED	27
EY 205	90-100	205	80"	230	685	9/48 ANGLED	27
EY 230	100-110	230	90"	255	735	10/54 ANGLED	27
EY 255	110-120	255	100"	280	785	11/60 ANGLED	27

ADDITIONAL EQUIPMENT UPON REQUEST

- Depth wheels
- Comer gearbox, type MZ-815 (P.T.O+ 8 cm height)
- Comer gearbox, type DZ-733 with 2 external speeds (P.T.O. + 12 cm height)
- Bonnet spring

Rotary Cultivator 130 EY/EYT **GEAR**

Fixed, super heavy-weighted rotary cultivator,
with 4 speeds, gear drive, 540 or 1000 P.T.O.
For tractors up to 130 H.P.



STANDARD EQUIPMENT

- Cardan shaft included
- Comer gearbox, type MZ-3A

Bridle 4 Industrial Area 4-A7
Z.I.P. 67025 Thessaloniki
T: 230289.0984-85
T: 230289.0989.88
F: 230289.0926.27
info@acker.gr
www.acker.gr



GEAR DRIVE

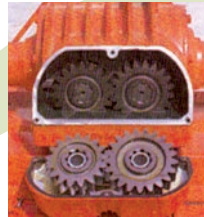

**COMER GEARBOX,
TYPE MZ-3A**

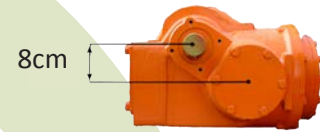

**COMER GEARBOX,
TYPE MZ-815**

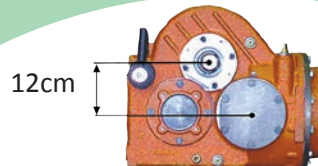

**COMER GEARBOX,
TYPE DZ-733**

TYPE	TRACTOR HORSEPOWER	WORKING WIDTH		TOTAL WIDTH	WEIGHT	NUMBER OF DISCS & BLADES		DEPTH OF WORK
	H.P.	cm	ins	cm	kg			cm
EY 180	70-90	180	70"	205	650	8/42	ANGLED	27
EY 205	90-100	205	80"	230	700	9/48	ANGLED	27
EY 230	100-110	230	90"	255	750	10/54	ANGLED	27
EY 255	110-120	255	100"	280	800	11/60	ANGLED	27
EY 280	120-130	280	110"	305	850	12/66	ANGLED	27

ADDITIONAL EQUIPMENT UPON REQUEST

- Depth wheels
- Comer gearbox, type MZ-815 (P.T.O. + 8 cm height)
- Comer gearbox, type DZ-733 with 2 external speeds (P.T.O. + 12 cm height)
- Bonnet spring

Rotary Cultivator 160 HY

High-powered rotary cultivator, with 4 speeds,
gear drive, 1000 P.T.O. For tractors up to 160 H.P.



STANDARD EQUIPMENT

- *Cardan shaft included*
- *Comer gearbox, type MZ-3A*



Rotary Cultivator 160 HY

Sindos Industrial Area 4-A7
 ZIP Code 57022, Thessaloniki
 T: +30 2310 79.79.84 -85
 T: +30 2310 79.99.88
 F: +30 2310 79.96.27
 info@acker.gr
 www.acker.gr



GEAR DRIVE



**COMER GEARBOX,
TYPE MZ-3A**

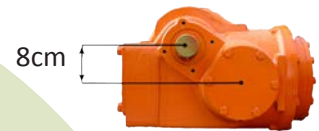

**COMER GEARBOX,
TYPE MZ-815**

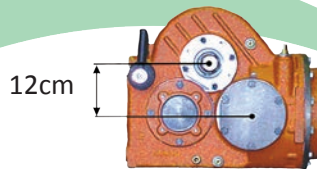

**COMER GEARBOX,
TYPE DZ-733**

TYPE	TRACTOR HORSEPOWER	WORKING WIDTH		TOTAL WIDTH	WEIGHT	NUMBER OF DISCS & BLADES	DEPTH OF WORK
	H.P.	cm	ins	cm	kg		cm
HY 205	100-110	205	80"	235	1050	9/48 ANGLED	30
HY 230	110-120	230	90"	260	1100	10/54 ANGLED	30
HY 255	120-130	255	100"	285	1150	11/60 ANGLED	30
HY 280	125-140	280	110"	310	1200	12/66 ANGLED	30
HY 305	130-160	305	120"	335	1250	13/72 ANGLED	30

ADDITIONAL EQUIPMENT UPON REQUEST

- Depth wheels
- Comer gearbox, type MZ-815 (P.T.O. + 8 cm height)
- Comer gearbox, type DZ-733 with two external speeds (P.T.O. + 12 cm height)
- Cooling-lubrication system
- Pair of frontal Ø360 discs
- Bonnet spring
- Teeth

Rotary Cultivator 200 H2Y ($z_1=22$)

High-powered rotary cultivator, with gear drive ($z_1=22$), 1000 P.T.O. For tractors up to 200 H.P.



TYPE	TRACTOR HORSEPOWER	WORKING WIDTH		TOTAL WIDTH	WEIGHT	NUMBER OF DISCS & BLADES	DEPTH OF WORK
	H.P.	cm	ins	cm	kg		cm
H2Y 330 $z_1=22$	160-180	330	130"	360	1300	14/78 ANGLD	30
H2Y 355 $z_1=22$	180-200	350	140"	385	1350	15/84 ANGLD	30
H2Y 380 $z_1=22$	200-220	380	150"	410	1400	16/90 ANGLD	30

STANDARD EQUIPMENT

- Cardan shaft included
- Comer gearbox, type MZ-827



Rotary Cultivator 200 H2Y ($z_1=22$)

Sindos Industrial Area 4-A7
ZIP Code 57022, Thessaloniki
T: +30 2310 79.79.84 -85
T: +30 2310 79.99.88
F: +30 2310 79.96.27
info@acker.gr
www.acker.gr

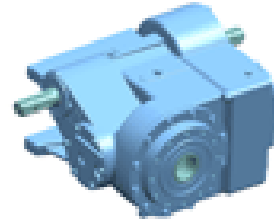

COMER GEARBOX,
TYPE MZ-827



ADDITIONAL EQUIPMENT UPON REQUEST

- Depth wheels
- Teeth
- Bonnet spring
- Pair of frontal Ø360 discs
- Cooling-lubrication system

Rotary Cultivator 250 H2Y

High-powered rotary cultivator, gear drive on 2 sides (z1=22), 1000 P.T.O. For tractors up to 250 H.P. Height of P.T.O. from the ground 95 cm.

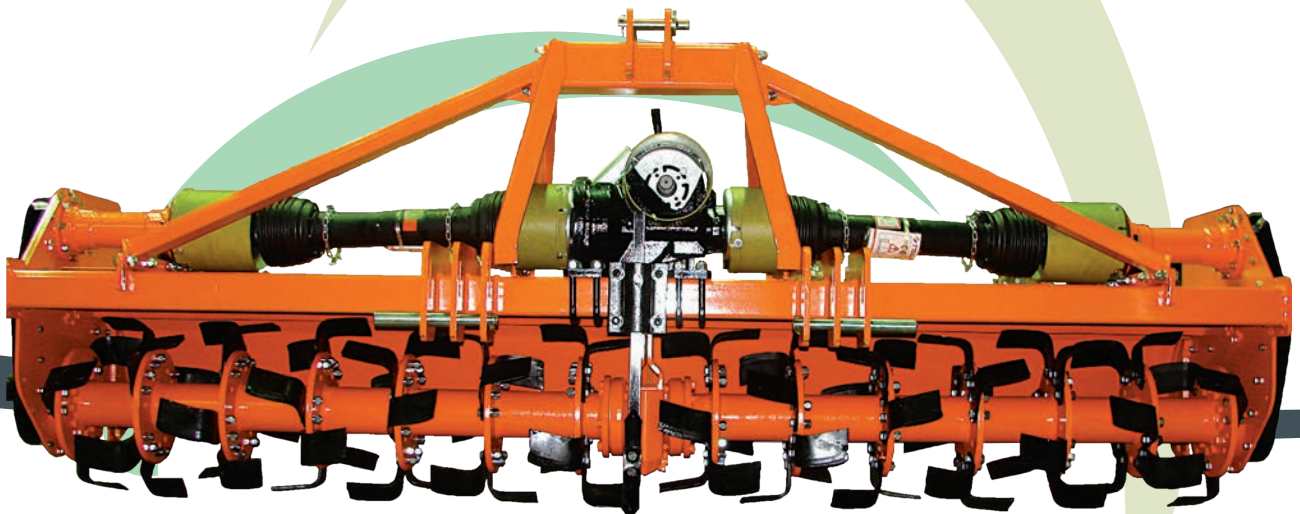

STANDARD EQUIPMENT

- *Cardan shaft included*
- *Comer gearbox, type D-825*
- *With three external speeds*



Rotary Cultivator 250 H2Y

Sindos Industrial Area 4-A7
 ZIP Code 57022, Thessaloniki
 T: +30 2310 79.79.84 -85
 T: +30 2310 79.99.88
 F: +30 2310 79.96.27
 info@acker.gr
 www.acker.gr

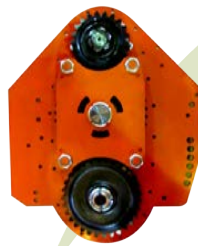

GEAR DRIVE



**COMER GEARBOX,
TYPE D-825**

TYPE	TRACTOR HORSEPOWER	WORKING WIDTH		TOTAL WIDTH	WEIGHT	NUMBER OF DISCS & BLADES	DEPTH OF WORK
	H.P.	cm	ins	cm	kg		cm
H2Y 330	160-180	330	130"	360	1300	14/78 ANGLED	30
H2Y 355	180-200	355	140"	385	1350	15/84 ANGLED	30
H2Y 380	200-220	380	150"	410	1400	16/90 ANGLED	30
H2Y 405	220-250	405	160"	435	1450	17/96 ANGLED	30

ADDITIONAL EQUIPMENT UPON REQUEST

- *Depth wheels*
- *Teeth*
- *Bonnet spring*
- *Pair of frontal Ø360 discs*
- *Cooling-lubrication system*

Rotary Cultivator 360 H2Y MP

High-powered rotary cultivator, gear drive, double sided cogwheels transmission with gear change possibility, 1000 P.T.O. Reducer with 1:1 ratio for tractors up to 360 H.P.



TYPE	TRACTOR HORSEPOWER	WORKING WIDTH	TOTAL WIDTH	DEPTH OF WORK
	H.P.	cm	cm	cm
HY MP 330	180-200	330	390	30
HY MP 355	200-220	355	415	30
HY MP 380	220-240	380	440	30
HY MP 405	240-260	405	465	30
HY MP 430	260-280	430	490	30
HY MP 455	280-300	455	515	30

STANDARD EQUIPMENT

- Cardan shaft included

ADDITIONAL EQUIPMENT UPON REQUEST

- Scraper
- Hitch for seeding machine
- Teeth
- Bonnet spring
- Pair of frontal Ø360 discs



Rotary Cultivator 360 H2Y HP

High-powered rotary cultivator, gear drive, double sided cogwheels transmission with gear change possibility, 1000 P.T.O. Reducer with 1:1 ratio for tractors up to 360 H.P. Gear-box and sided transmissions with oil cooling system.



TYPE	TRACTOR HORSEPOWER	WORKING WIDTH	TOTAL WIDTH	DEPTH OF WORK
	H.P.	cm	cm	cm
H2Y MP 330	200-220	330	390	30
H2Y MP 355	220-240	355	415	30
H2Y MP 380	240-260	380	440	30
H2Y MP 405	260-280	405	465	30
H2Y MP 430	280-300	430	490	30
H2Y MP 455	300-320	455	515	30

STANDARD EQUIPMENT

- Cardan shaft included

ADDITIONAL EQUIPMENT UPON REQUEST

- Depth wheels
- Scraper
- Hitch for seeding machine
- Teeth
- Bonnet spring
- Pair of frontal Ø360 discs



Rotary Cultivator 360 H2YFL

High-powered rotary cultivator, gear drive, double sided cogwheels transmission with gear change possibility, hydraulically folding, P.T.O. 1000 rpm. Reducer with 1:1 ratio for tractors up to 360 H.P.



TYPE	TRACTOR HORSEPOWER	WORKING WIDTH	TOTAL WIDTH	DEPTH OF WORK
	H.P.	cm	cm	cm
H2Y FL 440	220-250	440	490	30
H2Y FL 490	250-270	490	540	30
H2Y FL 540	270-290	540	590	30
H2Y FL 590	290-310	590	640	30

STANDARD EQUIPMENT

- Cardan shaft included

ADDITIONAL EQUIPMENT ON REQUEST

- Depth wheels
- Scraper
- Hitch for seeding machine
- Teeth
- Bonnet spring
- Pair of frontal Ø360 discs

Rotary Cultivator 240 E-ASM

Super heavy-weighted, folding rotary cultivator, gear drive, double sided cogwheels transmission with gear change possibility, P.T.O. 1000 rpm. Reducer with 1:1 ratio for tractors up to 240 H.P.

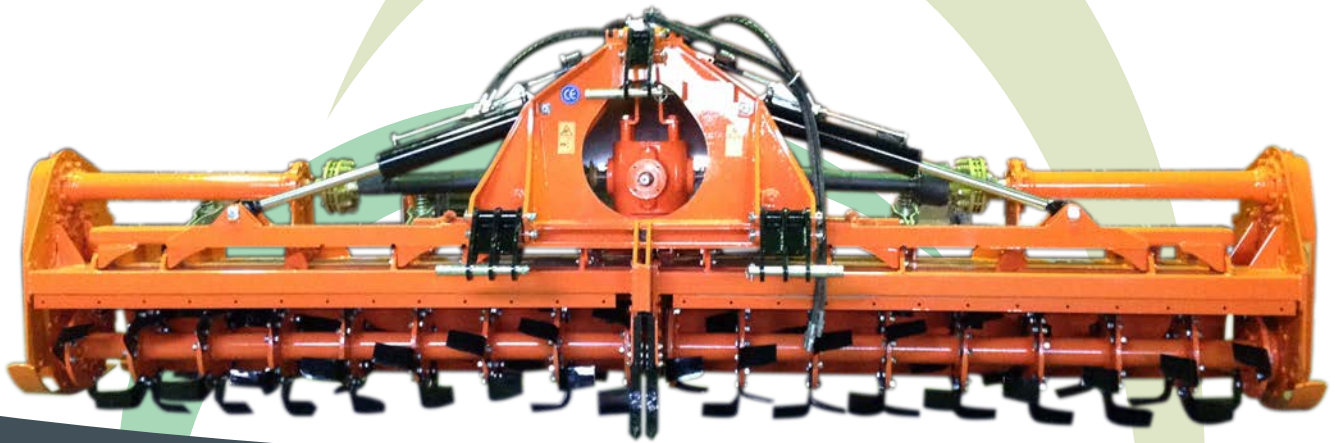

TYPE	TRACTOR HORSEPOWER	WORKING WIDTH	TOTAL WIDTH	WEIGHT	NUMBER OF DISCS & BLADES	DEPTH OF WORK
	H.P.	cm	cm	kg		cm
E-ASM 420	170-220	420	460	2500	18/96 ANGLD	25
E-ASM 470	190-240	470	510	2700	20/108 ANGLD	25

STANDARD EQUIPMENT

- Cardan shaft included

ADDITIONAL EQUIPMENT UPON REQUEST

- Teeth
- Bonnet spring
- Pair of frontal Ø360 discs



Cultivator SKN (F-H)

Fixed, medium heavy-weighted, reinforced agricultural cultivator, lateral transmission with gears, front-rear suspension, 1000 P.T.O. Suitable for asparagus cultivation, for dike processing. For tractors up to up to 75 H.P.



STANDARD EQUIPMENT

- *Cardan shaft included*
- *2 auxiliary elastic wheels*
- *Possibility of selection of blade-bearing axle rotations 245 U/min, 355 U/min, ή 568 U/min*

Cultivator SKN (F-H)

Sindos Industrial Area 4-A7
 ZIP Code 57022, Thessaloniki
 T: +30 2310 79.79.84 -85
 T: +30 2310 79.99.88
 F: +30 2310 79.96.27
 info@acker.gr
 www.acker.gr

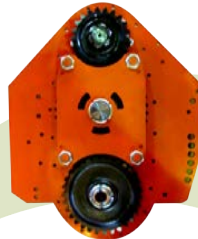

*Lateral transmission
 with gears, Modul=6*



TYPE	TRACTOR HORSEPOWER	WORKING WIDTH		NUMBER OF BLADES	WEIGHT
	H.P.	cm	ins	cm	kg
SK (F-H) 105	22-26	105	40"	24	270
SK (F-H) 130	30-35	130	50"	30	320
SK (F-H) 155	40-45	155	60"	36	370
SK (F-H) 180	50-55	180	70"	42	420
SK (F-H) 205	55-60	205	80"	48	470



Rotary cultivator E (F-H)

Fixed, heavy-weighted rotary cultivator with front - rear suspension, lateral transmission with gears, 1000 P.T.O. Suitable for the cultivation of asparagus, for dyke processing. For tractors up to 100 H.P.

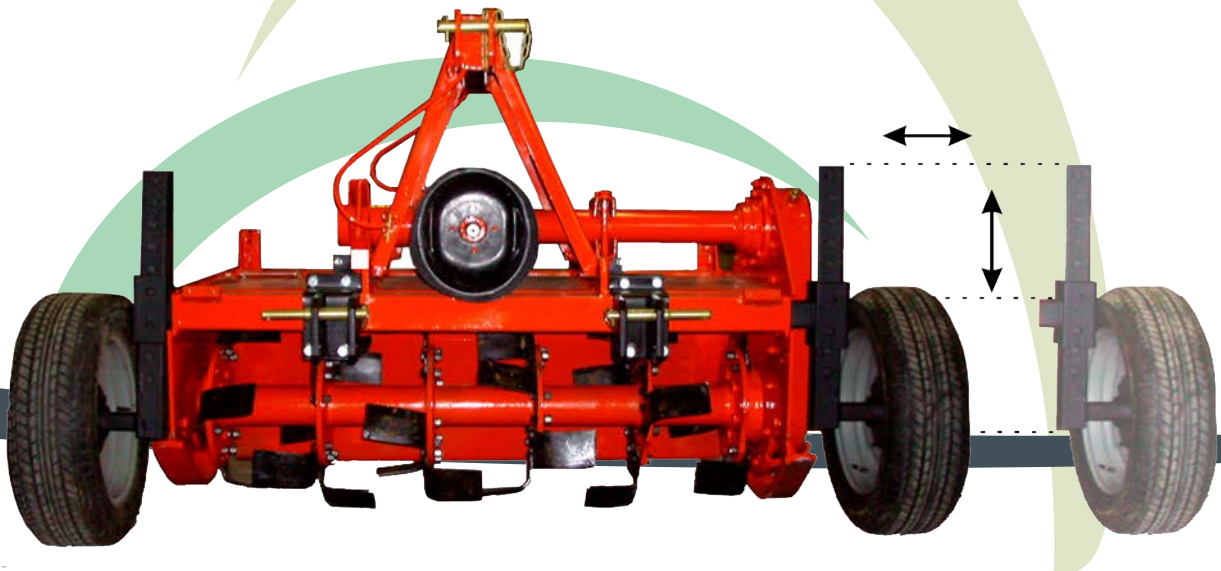

STANDARD EQUIPMENT

- Cardan shaft included
- 2 auxiliary elastic wheels
- Possibility of selection of blade-bearing axle rotations 245 U/min, 355 U/min, ή 568 U/min

Rotary cultivator E (F-H)

Sindos Industrial Area 4-A7
 ZIP Code 57022, Thessaloniki
 T: +30 2310 79.79.84 -85
 T: +30 2310 79.99.88
 F: +30 2310 79.96.27
 info@acker.gr
 www.acker.gr



GEAR DRIVE

TYPE	TRACTOR HORSEPOWER	WORKING WIDTH		NUMBER OF BLADES	WEIGHT
	H.P.	cm	ins	cm	kg
E (F-H) 105	35-40	105	40"	24	440
E (F-H) 130	45-50	130	50"	30	490
E (F-H) 155	55-60	155	60"	36	540
E (F-H) 180	65-70	180	70"	42	590

Rotary Cultivator 200 HY-R

High-powered rotary cultivator, lateral transmission with gears, 1000 P.T.O. Suitable for asparagus cultivation (dyke freshening). For tractors up to 200 H.P.

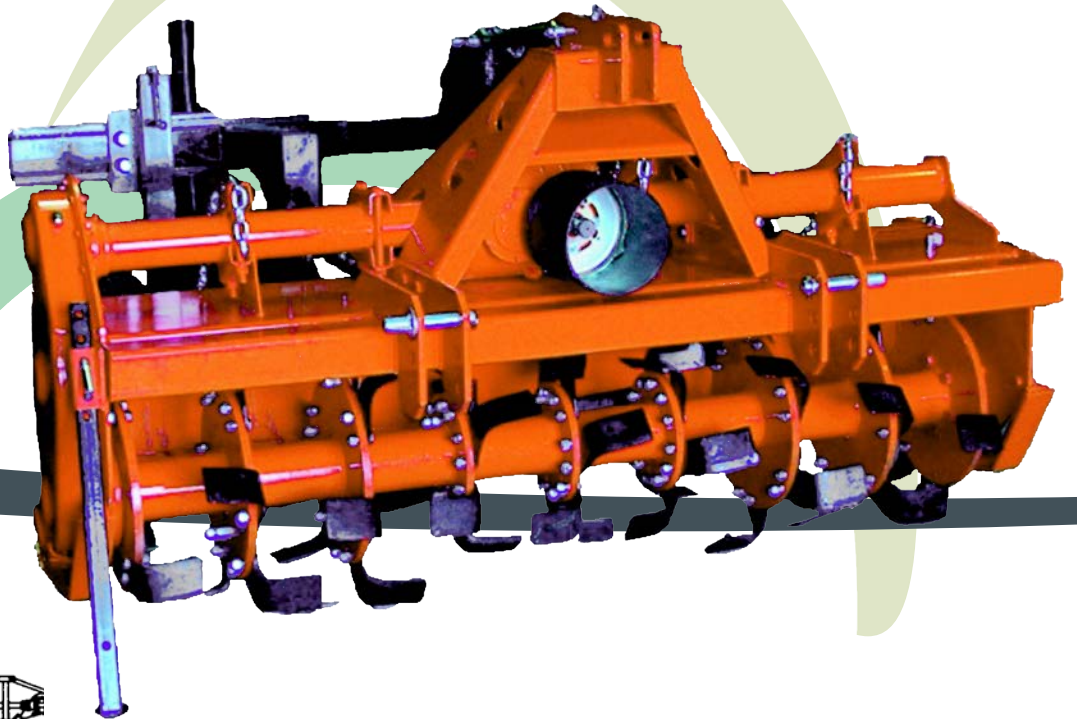
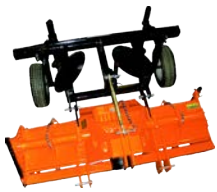

STANDARD EQUIPMENT

- *Cardan shaft included*
- *Comer gearbox, type MZ-3A*
- *Indicative speeds of blade-bearing axle (for P.T.O 1000 rpm): 154, 170, 194, 215, 250, 280 rpm*
- *Blade-bearing axle with a smaller cutting diameter at its centre*



Sindos Industrial Area 4-A7
ZIP Code 57022, Thessaloniki
T: +30 2310 79.79.84 -85
T: +30 2310 79.99.88
F: +30 2310 79.96.27
info@acker.gr
www.acker.gr



GEAR DRIVE

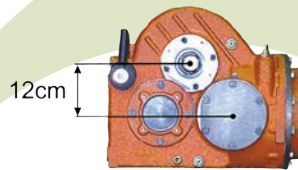

**COMER GEARBOX,
TYPE DZ-733**

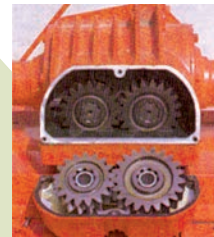

**COMER GEARBOX,
TYPE MZ-3A**

TYPE	TRACTOR HORSEPOWER	WORKING WIDTH		WORKING DEPTH	WEIGHT	DISTANCES FROM THE MACHINE CENTER		NUMBER OF BLADES
	H.P.	cm	ins	cm		cm	cm	
HY 180	90-100	210	80"	30	760	90	90	42
HY 205	100-110	235	90"	30	870	102	103	48
HY 230	110-120	260	100"	30	975	120	110	54
HY 255	120-130	285	110"	30	1080	120	135	60

ADDITIONAL EQUIPMENT UPON REQUEST

- **Comer gearbox, type DZ-733**
- **Installation of additional semi-circulars on the small-diameter discs, in order to achieve uniform depth of cutting**
- **Installation of a disc plough with a disc diameter of 660 - 710 mm - 800 mm**
- **Front - rear suspension**

Cultivator KVT E, SKN

System of two agricultural cultivators (heavy or medium-heavy type), for two intermediate dikes in asparagus cultivation.

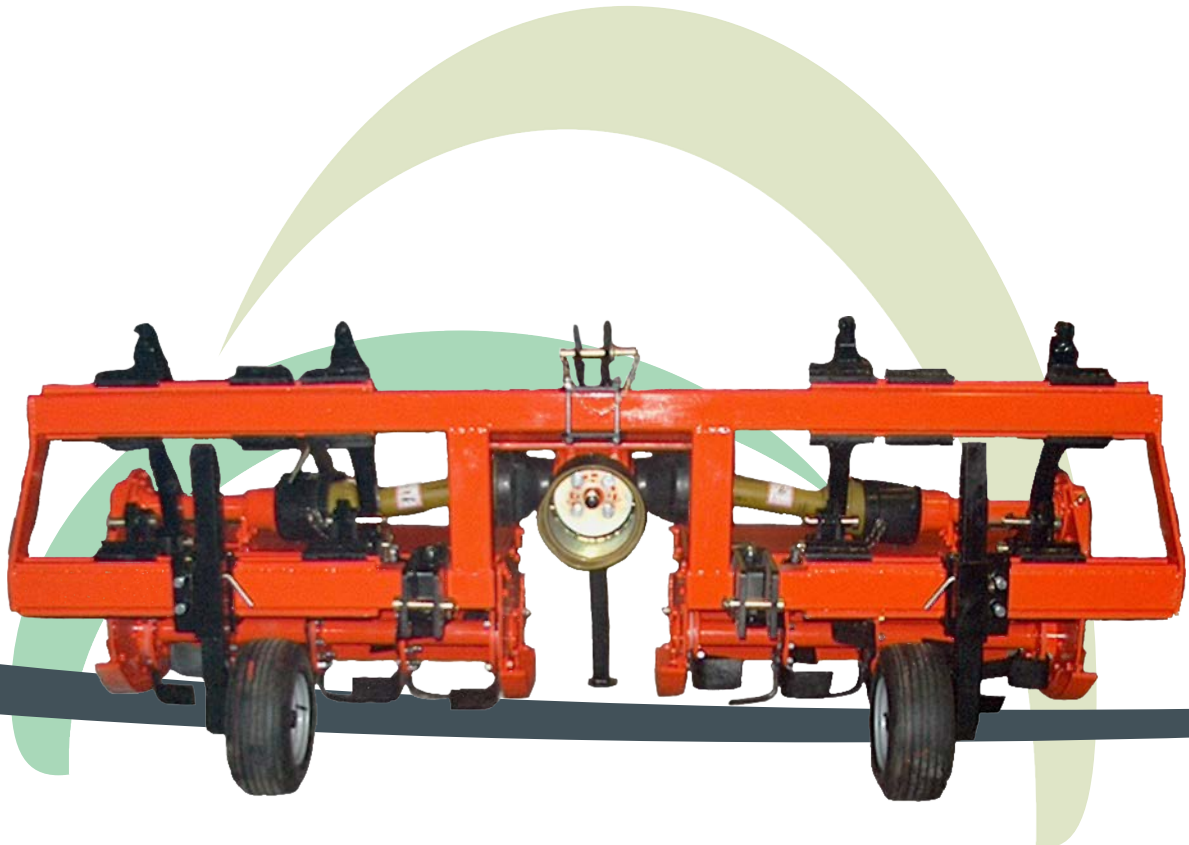

TYPE	WORKING WIDTH	TRACTOR HORSEPOWER	BLADES	WEIGHT
		H.P.		kg
KVT-E 105 WITH GEARWHEELS	2x105	80-85	2x24	980
KVT-SK 105 WITH GEARWHEELS	2x105	45-50	2x24	750

- **Capability of agricultural cultivators' placement at different cultivation width**

P.T.O	ROTATIONS RPM
540	190
750	263
1000	351

Disc harrow SE(N)

Attachable disc harrow, suitable for the cultivation of asparagus and other plants.

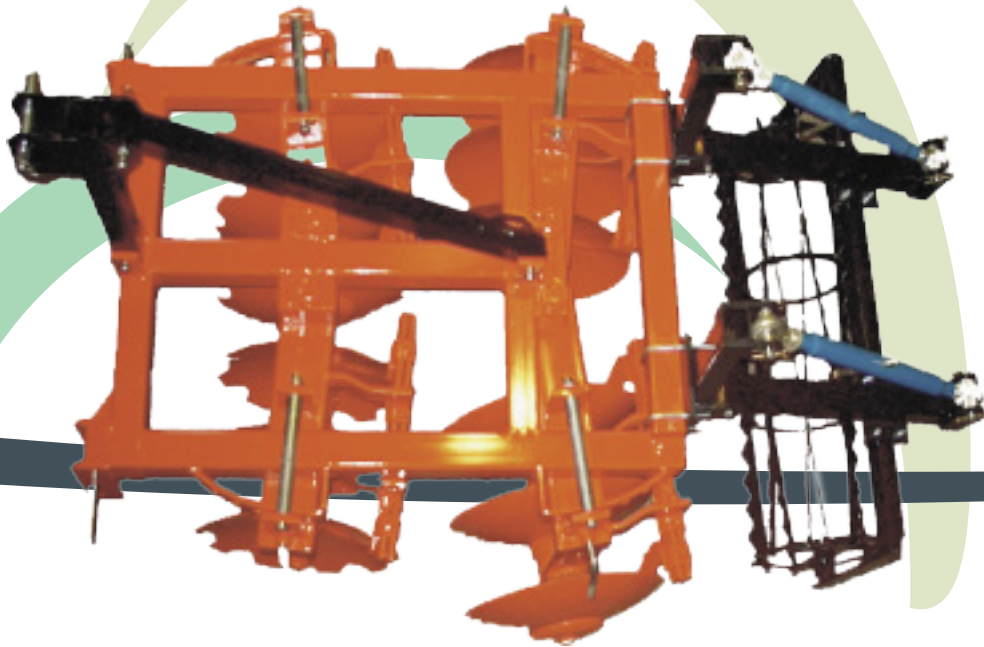

STANDARD EQUIPMENT

- *Three-point suspension for rear attachment category 1 and 2*
- *Adjustable pair of discs*
- *Includes a cogged cylinder*
- *Width of cultivation: 1200mm-1300mm*

ADDITIONAL EQUIPMENT UPON REQUEST

- *Hydraulically movable disc harrow*
- *4 discs per package*
- *Skew-angled roller bearings instead of simple roller bearings*
- *Hydraulic system for adjustable width of cutting*

Sindos Industrial Area 4-A7
 ZIP Code 57022, Thessaloniki
 T: +30 2310 79.79.84 -85
 T: +30 2310 79.99.88
 F: +30 2310 79.96.27
 info@acker.gr
 www.acker.gr

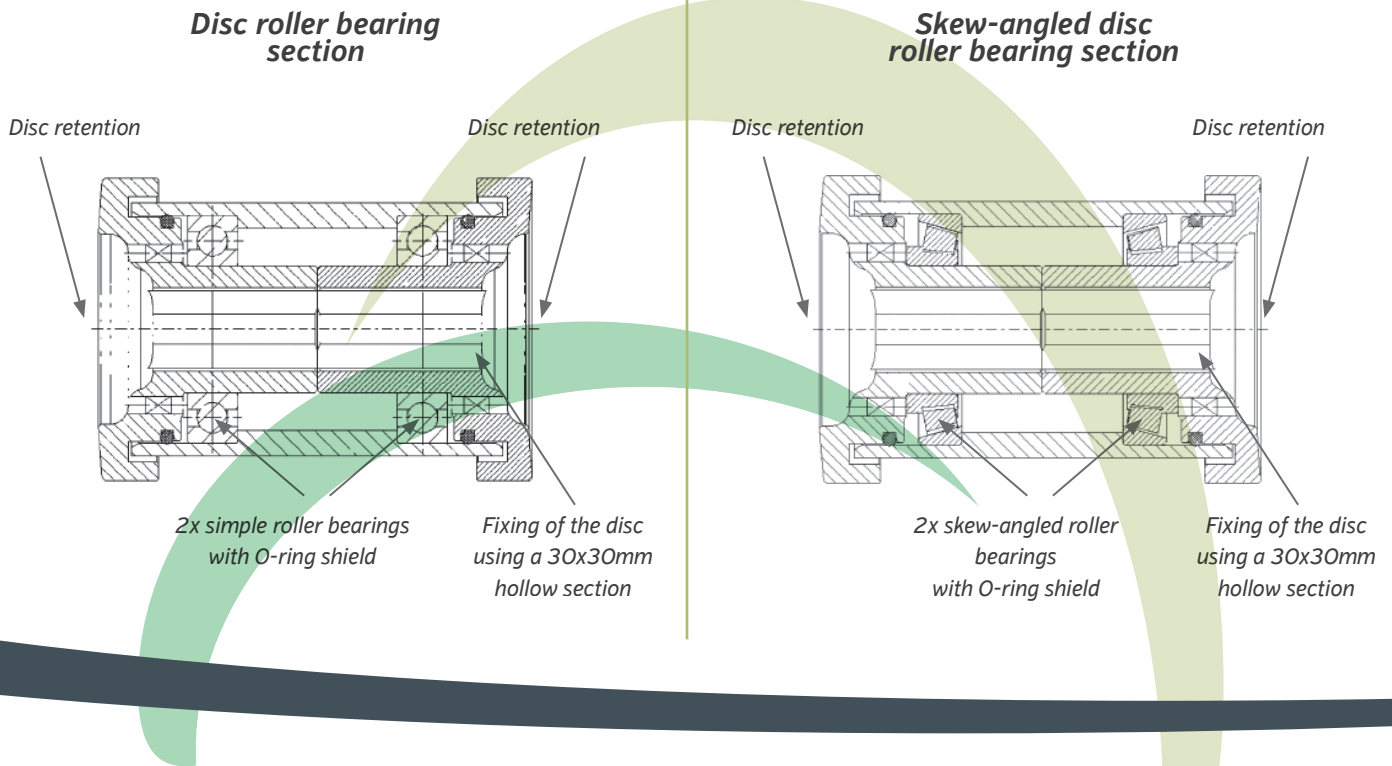

ΤΥΠΟΣ	NUMBER OF DISCS	WEIGHT	TYPE OF ROLLER
		kg	
RKL 550/12	12 - Ø510	450	Simple roller
RKL 550/12	12 - Ø510	450	Skew-angled roller

Disc plow SPR-DISK

Disc plow ideal for all agricultural operations related to the creation and fragmentation of dikes in the cultivation of asparagus.

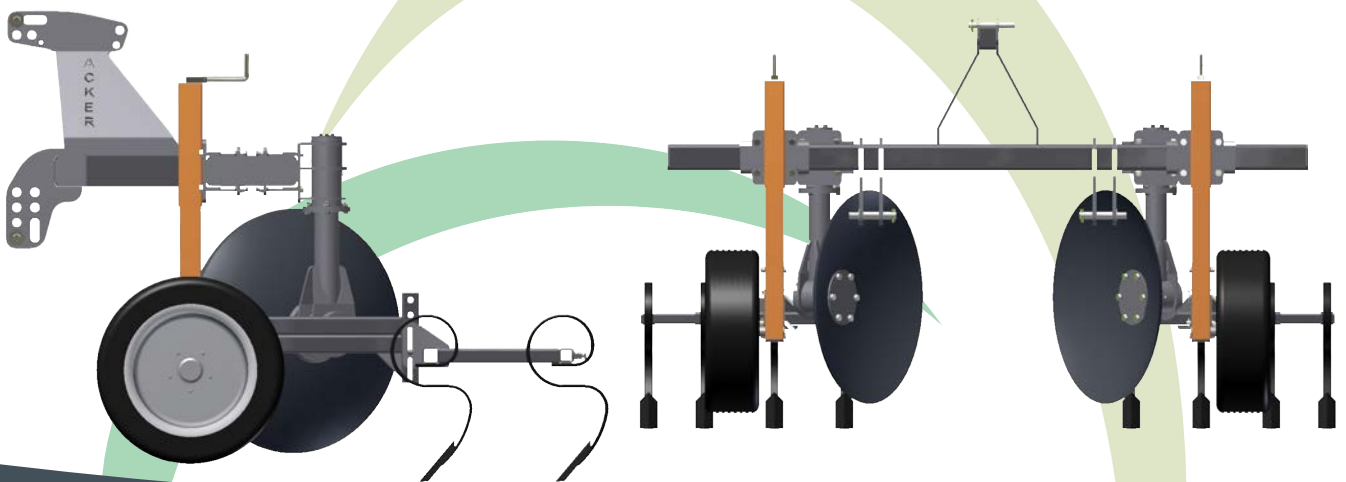

Flat plastic wrapper FWG(N)

System for the wrapping of flat plastic on cultivations with dikes.

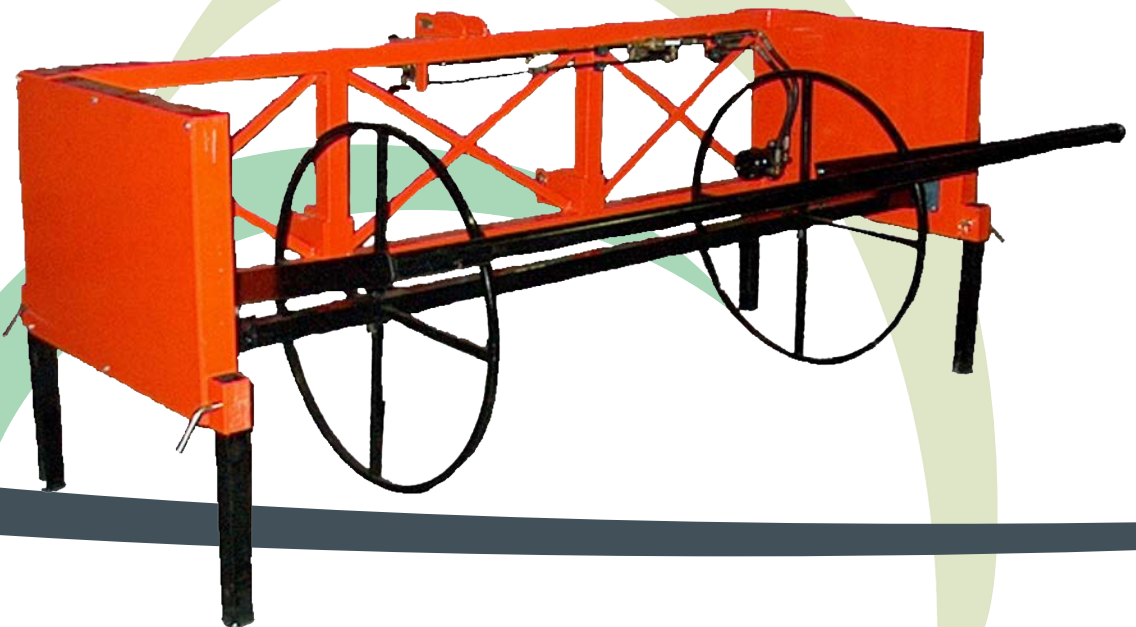

TYPE	MAXIMUM NYLON WIDTH	WORKING WIDTH
	mm	mm
FWG 2000	2000	2540

ADDITIONAL EQUIPMENT UPON REQUEST
NYLON WRAPPING DRIVE SYSTEM CONSISTING OF:

- *Mobile driving pipe*
- *Hydraulic cylinder*
- *Controller with lever*



Nylon covering FLG (N)

System for the spreading of flat plastic on cultivations with dikes (asparagus, etc.)

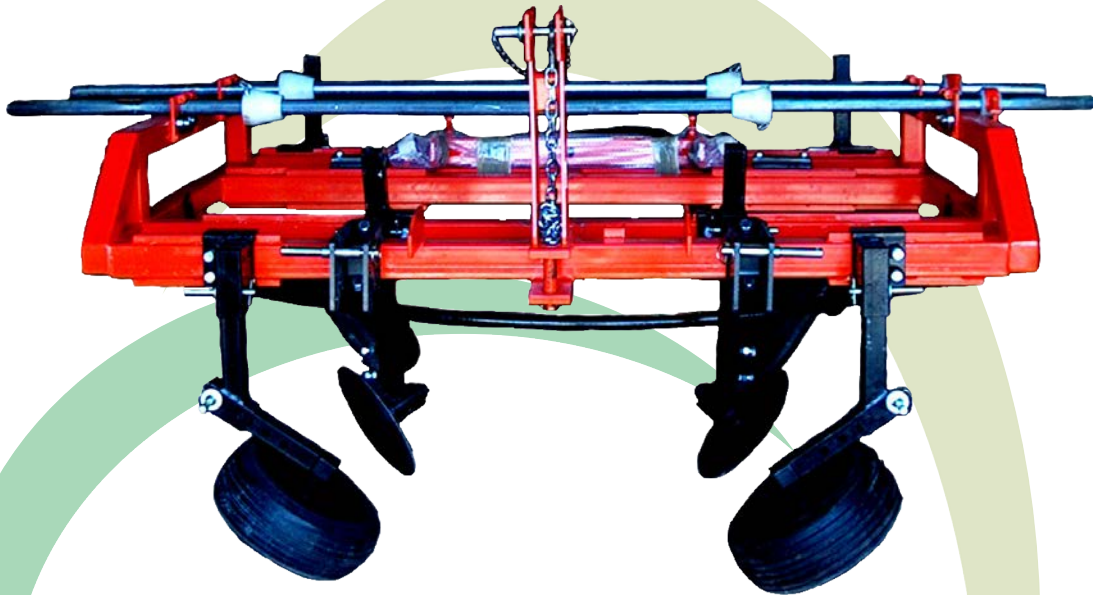

TYPE	MAXIMUM NYLON WIDTH	WORKING WIDTH
	mm	mm
FG 2000	2000	2540

STANDARD EQUIPMENT

- The machine will be used for all types of nylon
- The machine places the nylon on the ground and places soil on the sides for fastening
- The wheels and discs move in every position



Asparagus rotary cultivator SPR-GN

Cultivator for the creation of dikes in the cultivation of asparagus. Rotor distance of 1500mm, 540 P.T.O. For tractors up to 130 H.P.



GN: 1500mm

STANDARD EQUIPMENT

- *Required capacity: 60-100 H.P.*
- *Entry Axle: 1 3/4" z=6*
- *Motion transmission is performed by high-resistance gears*
- *Suitable for soft and hard soil*
- *Work speed: a) Creation of dyke 2-3 km/h b) Dyke freshening approximately 5 km/h*

Asparagus rotary cultivator SPR-GN

Sindos Industrial Area 4-A7
 ZIP Code 57022, Thessaloniki
 T: +30 2310 79.79.84 -85
 T: +30 2310 79.99.88
 F: +30 2310 79.96.27
 info@acker.gr
 www.acker.gr



GEAR DRIVE



PATENTED ROTOR WITH SLOTS FOR BLADES AND PEG SUPPORT, CAPABLE OF BEING SHIFTED 3 TIMES

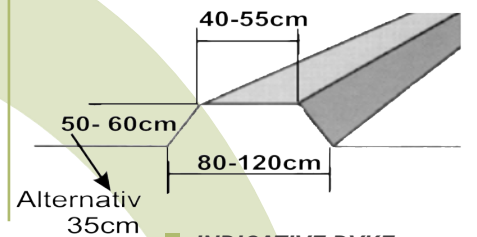

INDICATIVE DYKE DIMENSIONS

TYPE	WORKING WIDTH		TRACTOR HORSEPOWER	MAXIMUM CAPACITY	WEIGHT
	cm	ins	H.P.	H.P.	kg
160 SPR-GN	230	90"	60-100	130	950

ADDITIONAL EQUIPMENT UPON REQUEST

- *Dyke sprayer*
- *Internal teflon coating*
- *Installation of extra flexible springs (gare)*

Asparagus rotary cultivator SPR-GNY

Cultivator for the creation of dikes in the cultivation of asparagus. Rotor distance of 1650mm, 540 P.T.O. For tractors up to 130 H.P.



GNY: 1650mm



STANDARD EQUIPMENT

- *Required capacity: 60-100 H.P.*
- *Entry Axle: 1 3/4" z=6*
- *Motion transmission is performed by high-resistance gears*
- *Suitable for soft and hard soil*
- *Work speed: a) Creation of dyke 2-3 km/h b) Dyke freshening approximately 5 km/h*

Asparagus rotary cultivator SPR-GNY

Sindos Industrial Area 4-A7
 ZIP Code 57022, Thessaloniki
 T: +30 2310 79.79.84 -85
 T: +30 2310 79.99.88
 F: +30 2310 79.96.27
 info@acker.gr
 www.acker.gr



GEAR DRIVE



PATENTED ROTOR WITH SLOTS FOR BLADES AND PEG SUPPORT, CAPABLE OF BEING SHIFTED 3 TIMES

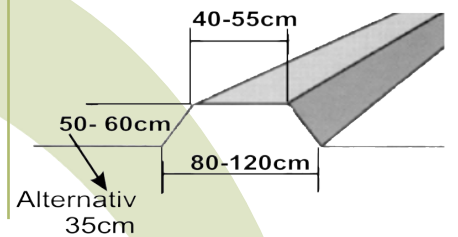

INDICATIVE DYKE DIMENSIONS

TYPE	WORKING WIDTH		TRACTOR HORSEPOWER	MAXIMUM CAPACITY	WEIGHT
	cm	ins	H.P.	H.P.	kg
160 SPR-GNY	230	90"	60-100	130	1000

ADDITIONAL EQUIPMENT UPON REQUEST

- *Dyke sprayer*
- *Internal teflon coating*
- *Installation of extra flexible springs (gare)*

Asparagus rotary cultivator SPR-GR

Cultivator for the creation of dikes in the cultivation of asparagus. Rotor distance of 1500mm, 1000 P.T.O. For tractors up to 160 H.P.

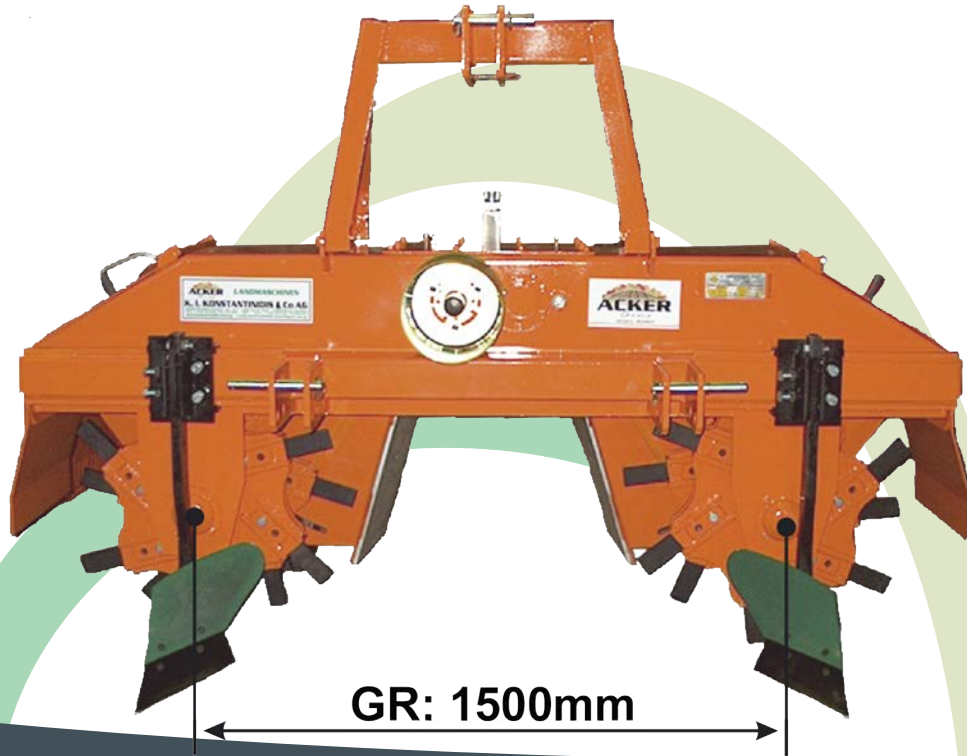

STANDARD EQUIPMENT

- **Required capacity: 110-140 H.P.**
- **Entry Axle: 13/4" z=6**
- **Motion transmission is performed by high-resistance gears**
- **The axles and gears are made of high quality, thermally processed steel (dyed)**
- **The rods (blades) are made of special steel with elastic and friction-resistant properties**
- **Suitable for soft and hard soil**
- **Work speed: a) Creation of dyke 2-3 km/h b) Dyke freshening approximately 5 km/h**

Asparagus rotary cultivator SPR-GR

Sindos Industrial Area 4-A7
ZIP Code 57022, Thessaloniki
T: +30 2310 79.79.84 -85
T: +30 2310 79.99.88
F: +30 2310 79.96.27
info@acker.gr
www.acker.gr



GEAR DRIVE

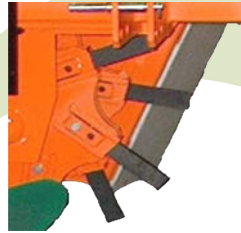

PATENTED ROTOR WITH SLOTS FOR BLADES AND PEG SUPPORT, CAPABLE OF BEING SHIFTED 3 TIMES

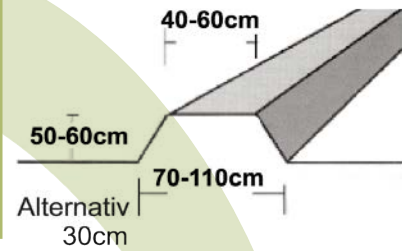

INDICATIVE DYKE DIMENSIONS

TYPE	WORKING WIDTH		TRACTOR HORSEPOWER	MAXIMUM CAPACITY	WEIGHT
	cm	ins	H.P.	H.P.	kg
160 SPR-GR	230	90"	90-140	160	1130

ADDITIONAL EQUIPMENT UPON REQUEST

- Dyke sprayer
- Internal teflon coating
- Installation of extra flexible springs (gare)

Asparagus rotary cultivator SPR-GR 150

This particular model is an improved and more robust version of the SPR-GR model. Enables adjustment of the dimension of the dyke, as well as the possibility of placing six or eight rows of knives, with screws or bolts, in the already existing patented rotor. 1000 P.T.O., for tractors up to 180 H.P.



Asparagus rotary cultivator SPR-GR 150

Sindos Industrial Area 4-A7
ZIP Code 57022, Thessaloniki
T: +30 2310 79.79.84 -85
T: +30 2310 79.99.88
F: +30 2310 79.96.27
info@acker.gr
www.acker.gr

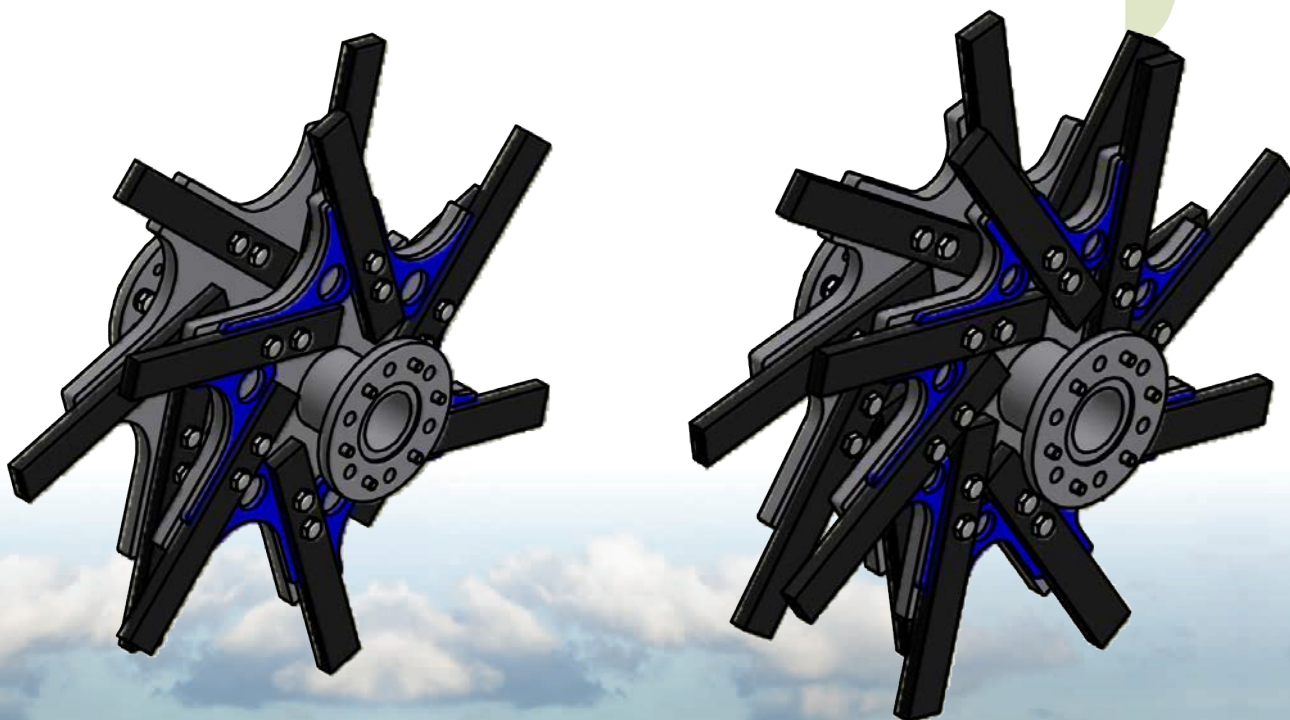
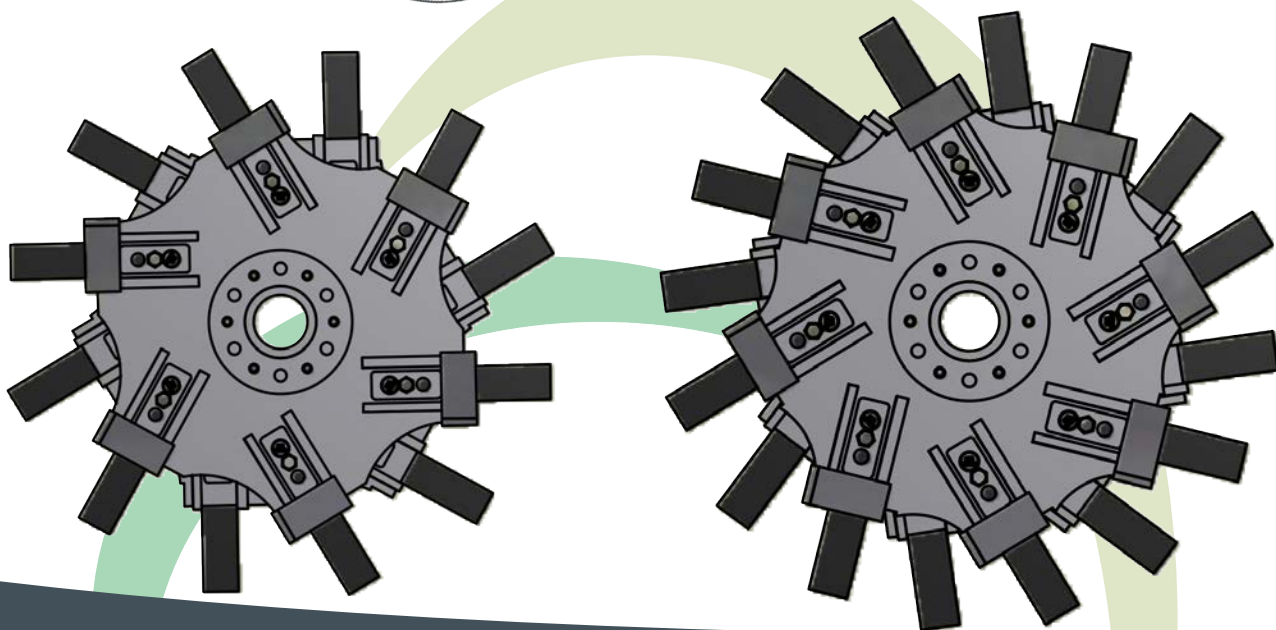

Asparagus rotary cultivator SPR-GRY

Cultivator for the creation of a dyke in the cultivation of asparagus. Rotor distance of 1650mm, 1000 P.T.O. For tractors up to 160 H.P.

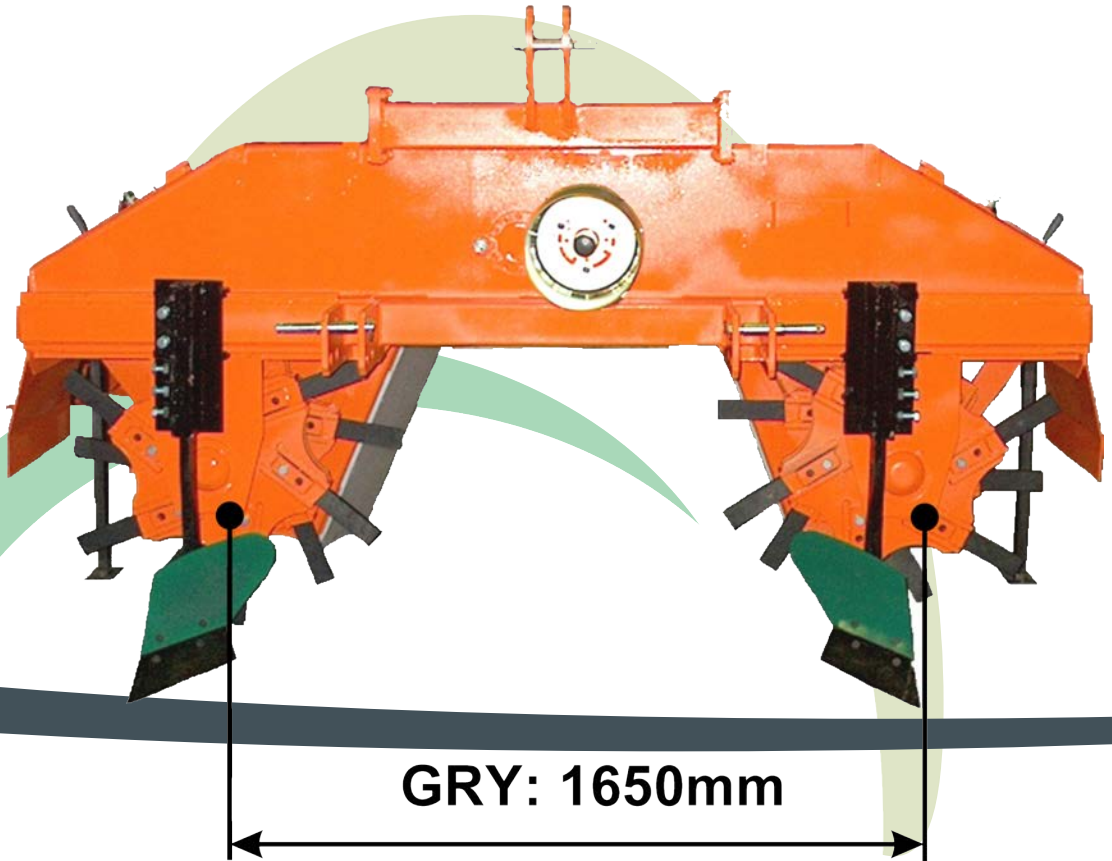

STANDARD EQUIPMENT

- **Required capacity:** 110-140 H.P.
- **Entry Axle:** 13/4" z=6
- **Motion transmission is performed by high-resistance gears**
- **The axles and gears are made of high quality, thermally processed steel (dyed)**
- **The rods (blades) are made of special steel with elastic and friction-resistant properties**
- **Suitable for soft and hard soil**
- **Work speed:** a) Creation of dyke 2-3 km/h b) Dyke freshening approximately 5 km/h

Asparagus rotary cultivator SPR-GRY

Sindos Industrial Area 4-A7
 ZIP Code 57022, Thessaloniki
 T: +30 2310 79.79.84 -85
 T: +30 2310 79.99.88
 F: +30 2310 79.96.27
 info@acker.gr
 www.acker.gr



GEAR DRIVE



PATENTED ROTOR WITH SLOTS FOR BLADES AND PEG SUPPORT, CAPABLE OF BEING SHIFTED 3 TIMES

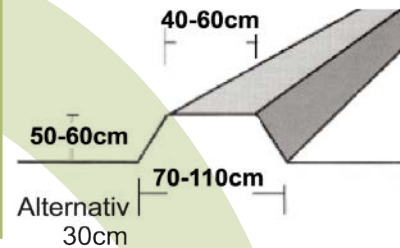

INDICATIVE DYKE DIMENSIONS

TYPE	WORKING WIDTH		REQUIRED CAPACITY	MAXIMUM CAPACITY	WEIGHT
	cm	ins	H.P.	H.P.	kg
160 SPR-GRY	270	106''	110 -140	160	1250

ADDITIONAL EQUIPMENT UPON REQUEST

- Dyke sprayer
- Internal teflon coating
- Installation of extra flexible springs (gare)

Asparagus rotary cultivator SPR-GB

Cultivator for the creation of dikes in the cultivation of asparagus. Rotor distance of 1500mm, 1000 P.T.O. For tractors up to 160 H.P.

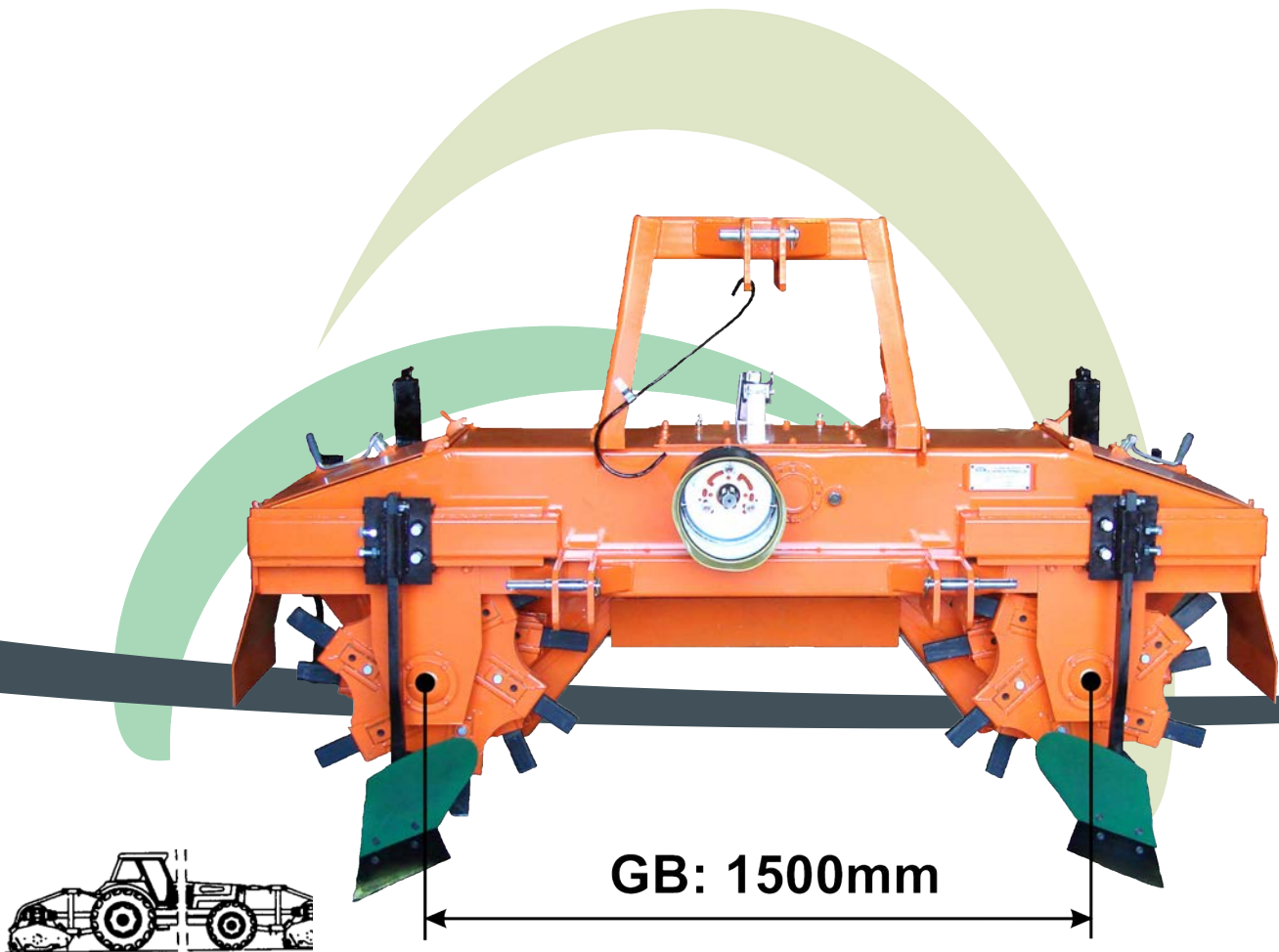

STANDARD EQUIPMENT

- **Required capacity: 110-140 H.P.**
- **Entry Axle: 1 3/4" z=26**
- **Motion transmission is performed by high-resistance gears**
- **The axles and gears are made of high quality, thermally processed steel (dyed)**
- **The rods (blades) are made of special steel with elastic and friction-resistant properties**
- **Suitable for soft and hard soil**
- **Work speed: a) Creation of dyke 2-3 km/h b) Dyke freshening approximately 5 km/h**

Asparagus rotary cultivator SPR-GB

Sindos Industrial Area 4-A7
 ZIP Code 57022, Thessaloniki
 T: +30 2310 79.79.84 -85
 T: +30 2310 79.99.88
 F: +30 2310 79.96.27
 info@acker.gr
 www.acker.gr



GEAR DRIVE

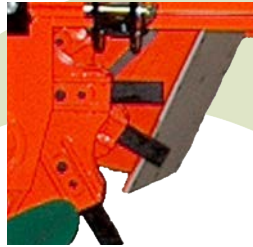

PATENTED ROTOR WITH SLOTS FOR BLADES AND PEG SUPPORT, CAPABLE OF BEING SHIFTED 3 TIMES

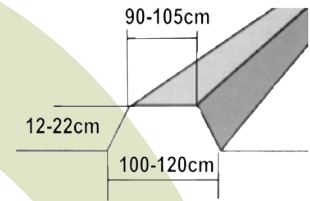

INDICATIVE DYKE DIMENSIONS



TYPE	WORKING WIDTH		TRACTOR HORSEPOWER	MAXIMUM CAPACITY	WEIGHT
	cm	ins	H.P.	H.P.	kg
160 SPR-GB	250	98"	110-140	160	1130

ADDITIONAL EQUIPMENT UPON REQUEST

- *Dyke sprayer*
- *Internal teflon coating*
- *Installation of extra flexible springs (gare)*

Asparagus rotary cultivator SPR-GBY

Cultivator for the creation of dikes in the cultivation of asparagus. Rotor distance of 1650mm, 1000 P.T.O. For tractors up to 160 H.P.

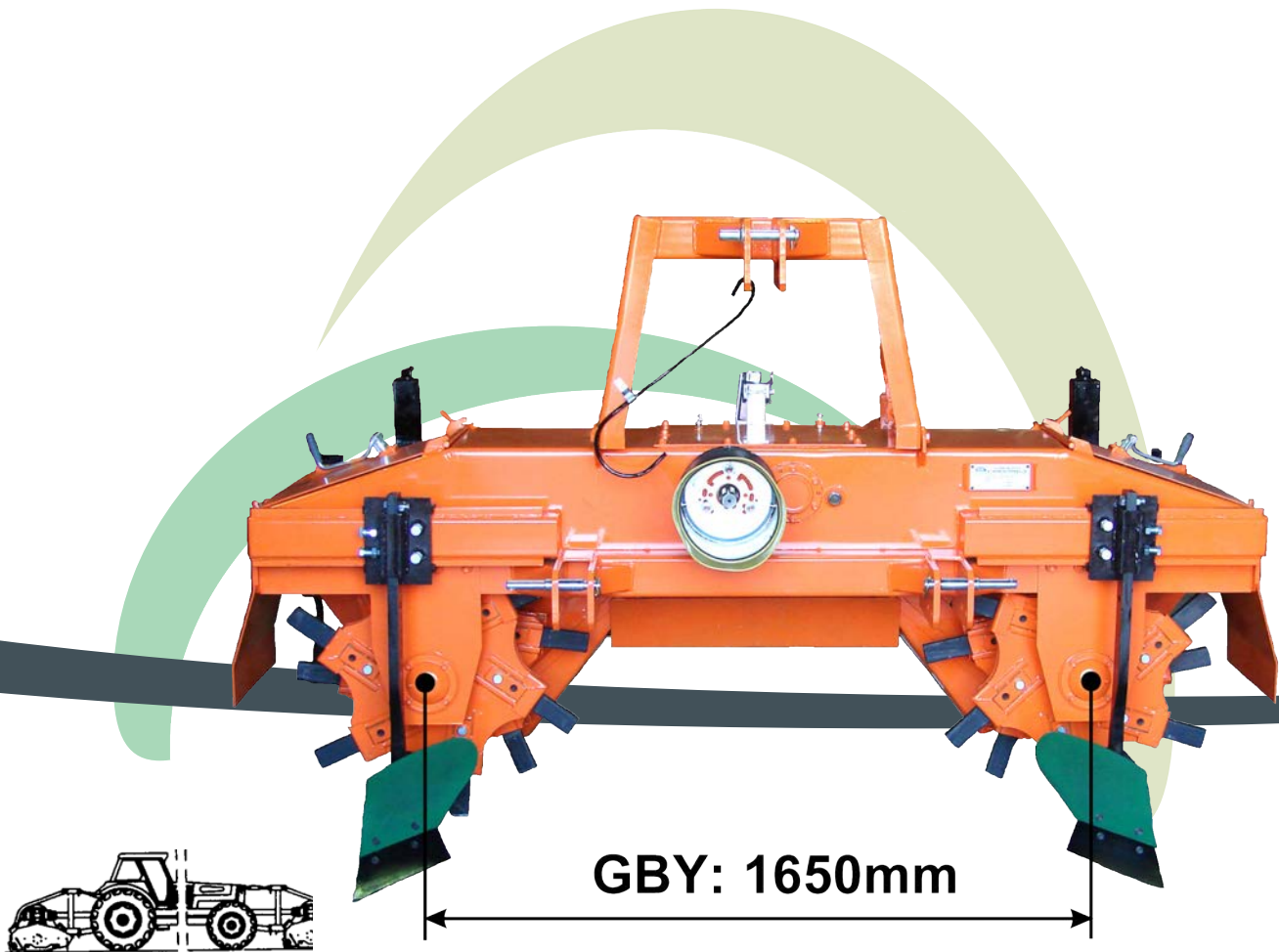

STANDARD EQUIPMENT

- **Required capacity: 110-140 H.P.**
- **Entry Axle: 1 3/4" z=26**
- **Motion transmission is performed by high-resistance gears**
- **The axles and gears are made of high quality, thermally processed steel (dyed)**
- **The rods (blades) are made of special steel with elastic and friction-resistant properties**
- **Suitable for soft and hard soil**
- **Work speed: a) Creation of dyke 2-3 km/h b) Dyke freshening approximately 5 km/h**

Asparagus rotary cultivator SPR-GBY

Sindos Industrial Area 4-A7
 ZIP Code 57022, Thessaloniki
 T: +30 2310 79.79.84 -85
 T: +30 2310 79.99.88
 F: +30 2310 79.96.27
 info@acker.gr
 www.acker.gr



GEAR DRIVE

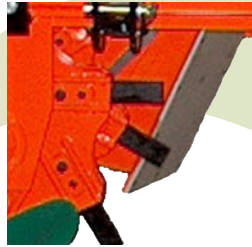

PATENTED ROTOR WITH SLOTS FOR BLADES AND PEG SUPPORT, CAPABLE OF BEING SHIFTED 3 TIMES

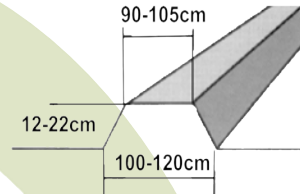

INDICATIVE DYKE DIMENSIONS



TYPE	WORKING WIDTH		TRACTOR HORSEPOWER	MAXIMUM CAPACITY	WEIGHT
	cm	ins	H.P.	H.P.	kg
160 SPR-GBY	250	98"	130-150	160	1130

ADDITIONAL EQUIPMENT UPON REQUEST

- *Dyke sprayer*
- *Internal teflon coating*
- *Installation of extra flexible springs (gare)*



Asparagus rotary cultivator SPR-GSN

Cultivator for the creation of dikes in the cultivation of asparagus. Rotor distance of 1650mm, 1000 P.T.O. For tractors up to 180 H.P.



GSN: 1650mm

STANDARD EQUIPMENT

- Required capacity: 100-150 H.P.
- Entry Axle: 13/4" z=6
- Front - rear suspension
- Motion transmission is performed by high-resistance gears
- The axles and gears are made of high quality, thermally processed steel (dyed)
- The rods (blades) are made of special steel with elastic and friction-resistant properties
- Suitable for soft and hard soil
- Work speed: a) Creation of dyke 2-3 km/h b) Dyke freshening approximately 5 km/h

Asparagus rotary cultivator SPR-GSN

Sindos Industrial Area 4-A7
 ZIP Code 57022, Thessaloniki
 T: +30 2310 79.79.84 -85
 T: +30 2310 79.99.88
 F: +30 2310 79.96.27
 info@acker.gr
 www.acker.gr



GEAR DRIVE

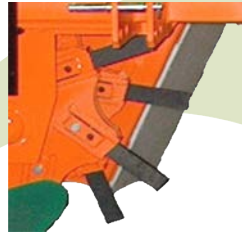

PATENTED ROTOR WITH SLOTS FOR BLADES AND PEG SUPPORT, CAPABLE OF BEING SHIFTED 3 TIMES

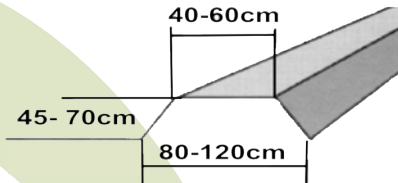

INDICATIVE DYKE DIMENSIONS

TYPE	WORKING WIDTH		TRACTOR HORSEPOWER	MAXIMUM CAPACITY	WEIGHT
	cm	ins			
160 SPR-GS(N)	270	106"	100-150	180	1650

ADDITIONAL EQUIPMENT UPON REQUEST

- *Dyke sprayer*
- *Internal teflon coating*
- *Installation of extra flexible springs (gare)*

Asparagus rotary cultivator SPR-GSY

Cultivator for the creation of a dyke in the cultivation of asparagus. Rotor distance of 1650mm, 1000 P.T.O. For tractors up to 250 H.P.



GSY: 1650mm

STANDARD EQUIPMENT

- **Required capacity: 160 H.P.**
- **Entry Axle: 1 3/4" z=20**
- **Motion transmission is performed by high-resistance gears**
- **The axles and gears are made of high quality, thermally processed steel (dyed)**
- **The rods (blades) are made of special steel with elastic and friction-resistant properties**
- **Selection of rotor diameter: 900mm or 1000mm**
- **Suitable for soft and hard soil**
- **Work speed: a) Creation of dyke 2-3 km/h b) Dyke freshening approximately 5 km/h**

Asparagus rotary cultivator SPR-GSY

Sindos Industrial Area 4-A7
 ZIP Code 57022, Thessaloniki
 T: +30 2310 79.79.84 -85
 T: +30 2310 79.99.88
 F: +30 2310 79.96.27
 info@acker.gr
 www.acker.gr



GEAR DRIVE

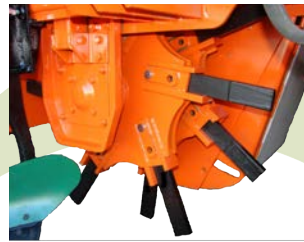

PATENTED ROTOR WITH SLOTS FOR BLADES AND PEG SUPPORT, CAPABLE OF BEING SHIFTED 3 TIMES, REINFORCED ROTORS WITH ANGLES

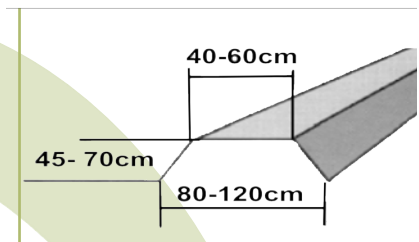

INDICATIVE DYKE DIMENSIONS

TYPE	WORKING WIDTH		TRACTOR HORSEPOWER	MAXIMUM CAPACITY	WEIGHT
	cm	ins	H.P.	H.P.	kg
250 SPR-GS(Y)	286	112"	160-180	250	2160

ADDITIONAL EQUIPMENT ON REQUEST

- Dyke sprayer
- Internal teflon coating
- Installation of extra flexible springs (gare)

Asparagus rotary cultivator SPR-GFY

Rotary cultivator for dyke creation in asparagus cultivation. Rotor distance of 1650mm, 540 P.T.O. Front - sided cogwheel transmission. For tractors up to 230 H.P.



TYPE	WORKING WIDTH		TRACTOR HORSEPOWER	MAXIMUM CAPACITY	WEIGHT
	cm	ins	H.P.	H.P.	kg
SPR-GFY 165	270	106"	130-170	230	1950

STANDARD EQUIPMENT

- Recommended power: 130-170 H.P.
- Entry Axle: 1 3/4": z=6
- Very strong gear transmission system with Module 7 and 8

ADDITIONAL EQUIPMENT UPON REQUEST

- Internal coating with teflon

Asparagus rotary cultivator SPR-GFY

Sindos Industrial Area 4-A7
 ZIP Code 57022, Thessaloniki
 T: +30 2310 79.79.84 -85
 T: +30 2310 79.99.88
 F: +30 2310 79.96.27
 info@acker.gr
 www.acker.gr

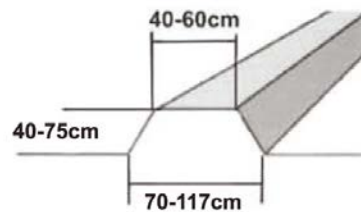

**PATENDED ROTOR WITH EXTRA
 ANTIFRICTION COVERED BLADES
 WHICH ARE SCREWED IN 3
 DIFFERENT POSITIONS**

**INDICATIVE DIMENSIONS
 OF DIKES**

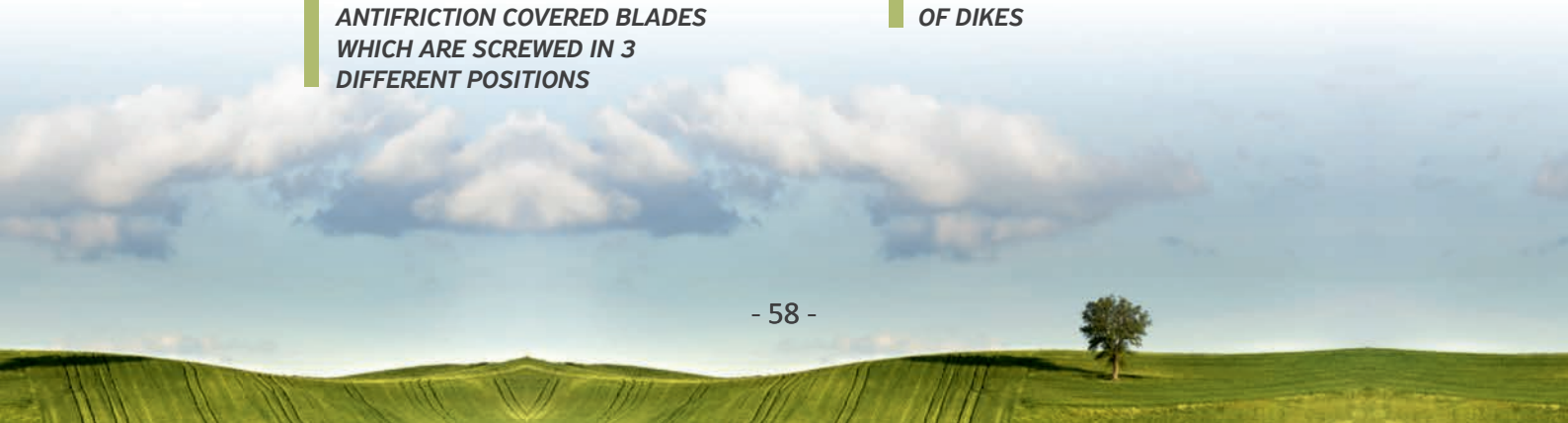

Shredder KTS – FU(N) SPR

Super heavy-weighted agricultural shredder for the cultivation of asparagus, 1000 P.T.O., with LS hammers (75mm). For tractors up to 120 H.P.



STANDARD EQUIPMENT

- *Suspension of three points front – rear cat.2*
- *Elastic wheel, height and width adjustable 170x70x13.*
- *Comer gearbox T-312 (with rolip)*
- *Cardan shaft included*
- *Adjustable front cover*



Shredder KTS – FU(N) SPR

Sindos Industrial Area 4-A7
 ZIP Code 57022, Thessaloniki
 T: +30 2310 79.79.84 -85
 T: +30 2310 79.99.88
 F: +30 2310 79.96.27
 info@acker.gr
 www.acker.gr

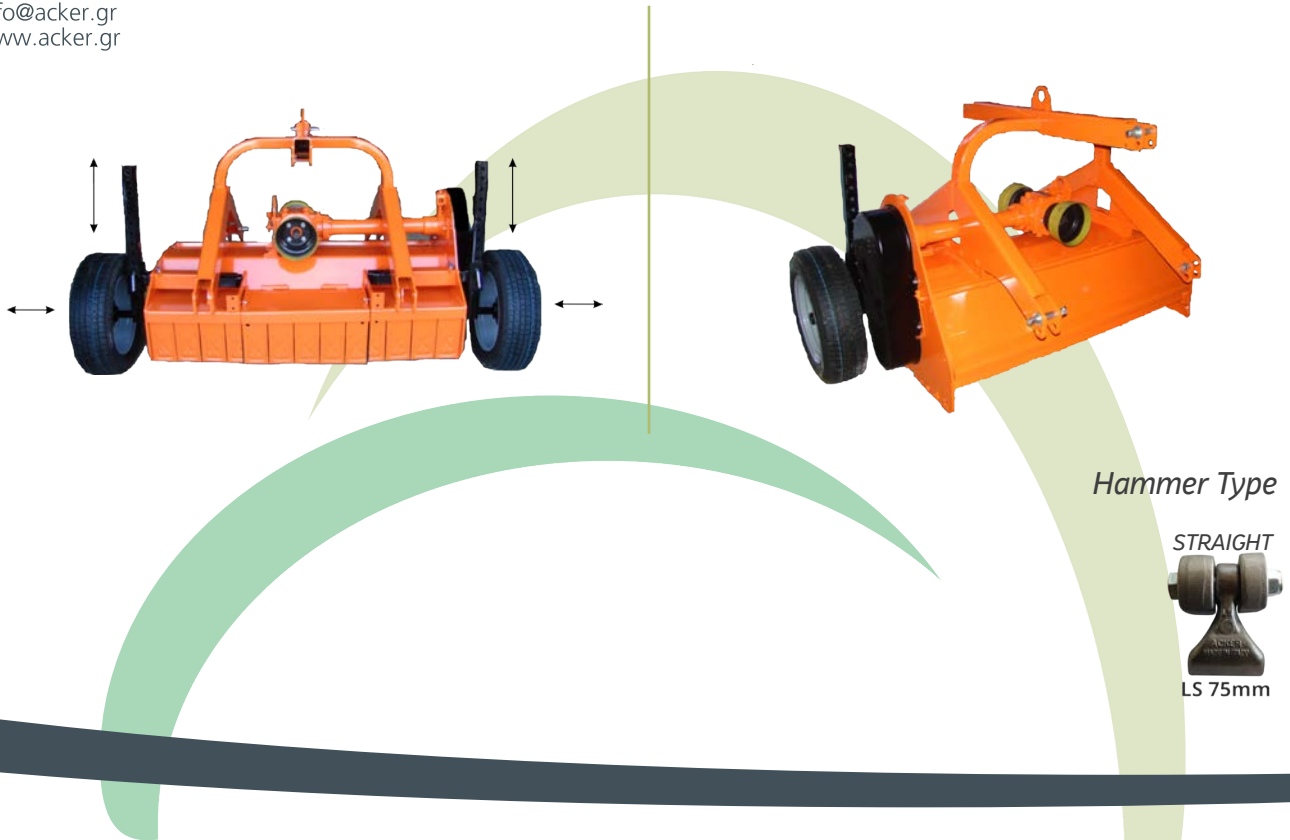

TYPE	WORKING WIDTH	TRACTOR HORSEPOWER	HAMMERS	WEIGHT
	mm	H.P.	LS	kg
KTS-FU(N)-SPR 135	1350	50	20	580
KTS-FU(N)-SPR 150	1500	60	24	620
KTS-FU(N)-SPR 162	1625	70	24	670
KTS-FU(N)-SPR 175	1750	80	28	745
KTS-FU(N)-SPR 200	2000	90	32	805

Shredder KTS – SPR

Super heavy-weighted agricultural shredder for the cultivation of asparagus. 1000 P.T.O., with LS hammers (75mm). For tractors up to 120 H.P.



KTS – SPRF

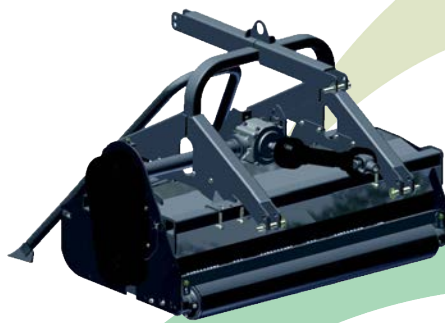

STANDARD EQUIPMENT

- Suspension of three points front – rear cat.2
- Elastic wheel, height and width adjustable 170x70x13
- Comer gearbox, type T-312 (with rolip)
- Cardan shaft included
- Adjustable front cover
- Manually movable

KTS – SPRV



STANDARD EQUIPMENT

- Suspension of three points front – rear cat.2
- Elastic wheel, height and width adjustable 170x70x13
- Comer gearbox, type T-312 (with rolip)
- Cardan shaft included
- Adjustable front cover
- Hydraulically movable (right - left)

Shredder KTS F(N) S

Super heavy-weighted, folding agricultural shredder for asparagus cultivation, with LS hammers (75mm). For tractors up to 120 H.P.



TYPE	WORKING WIDTH	TOTAL WIDTH	TRACTOR HORSEPOWER	HAMMERS	WEIGHT
	mm	mm	H.P.	LS	kg
KTS-F(N) S-150	1500	4150	40-60	24	880
KTS-F(N) S-162	1620	4270	50-60	24	950
KTS-F(N) S-175	1750	4400	60-70	28	1020
KTS-F(N) S-200	2000	4650	70-80	32	1100
KTS-F(N) S-225	2250	4900	80-90	36	1180
KTS-F(N) S-250	2500	5150	90-100	40	1250
KTS-F(N) S-275	2750	5400	100-110	44	1320
KTS-F(N) S-300	3000	5650	110-120	48	1400

STANDARD EQUIPMENT

- Adjustable front cover
- Support wheels
- Front - rear suspension
- Allowable counterweight
- Width of tilt 90° to 10°
- Cardan shaft included

Hammer type

STRAIGHT



LS 75mm

Rotor diameter 205 mm
P.T.O. 1000

KTS - SPR AS (folding Shredder)

Double, folding, shredding system for the cultivation of asparagus, with the possibility of choosing rotor diameter of 160 or 205mm with LS hammers (75mm).



Hammer type

STRAIGHT



LS 75mm

Rotor diameter 160 ή 205 mm
 P.T.O. 540 or 1000

MACHINE SPECIFICATIONS

- Working width (2x150cm)
- Consists of two asparagus shredders with a central gearbox transmission
- Rotor distance 160 or 205mm
- The shredders can be hydraulically suspended
- Hammer type LS (75mm)
- P.T.O 540 or 1000 r.p.m
- Cardan shaft included
- Supporting cylinder (on request)

KTS - SPR AS (folding Shredder)

Sindos Industrial Area 4-A7
ZIP Code 57022, Thessaloniki
T: +30 2310 79.79.84 -85
T: +30 2310 79.99.88
F: +30 2310 79.96.27
info@acker.gr
www.acker.gr

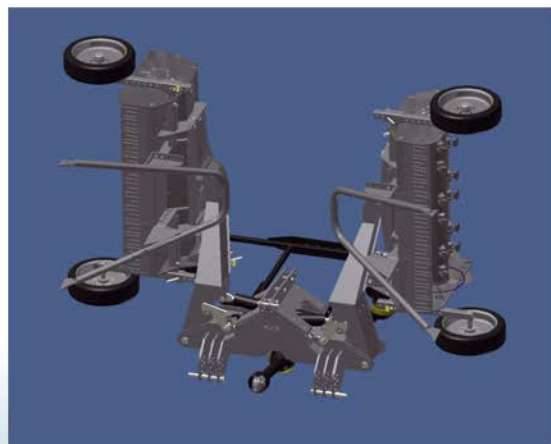
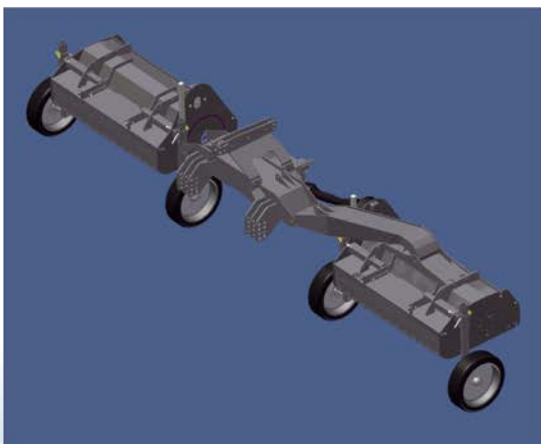

Shredder KTS - M

Ultra-lightweight agricultural shredder, with LS hammers (75mm). For tractors up to 25 H.P.



TYPE	WORKING WIDTH	TOTAL WIDTH	TRACTOR HORSEPOWER	HAMMERS	WEIGHT
	mm	mm	H.P.	LS	kg
KTS-M 80	800	975	12-15	12	145
KTS-M 90	900	1275	15-18	16	165
KTS-M 100	1000	1175	18-20	16	180
KTS-M 110	1100	1275	20-22	20	200
KTS-M 125	1250	1425	22-25	20	215

STANDARD EQUIPMENT

- Motion transmission with 3 belts
- Comer gearbox, type T-310 (with rolip)
- Support pedals
- Cardan shaft included

ADDITIONAL EQUIPMENT UPON REQUEST

- Support cylinder

Hammer type

STRAIGHT



LS 75mm

Rotor diameter 108 mm
 P.T.O. 540

Shredder KTS LD

Fixed, light-weighted agricultural shredder, with LS hammers (75mm). For tractors up to 60 H.P.



Hammer type

STRAIGHT



LS 75mm

Rotor diameter 133 mm
P.T.O. 540

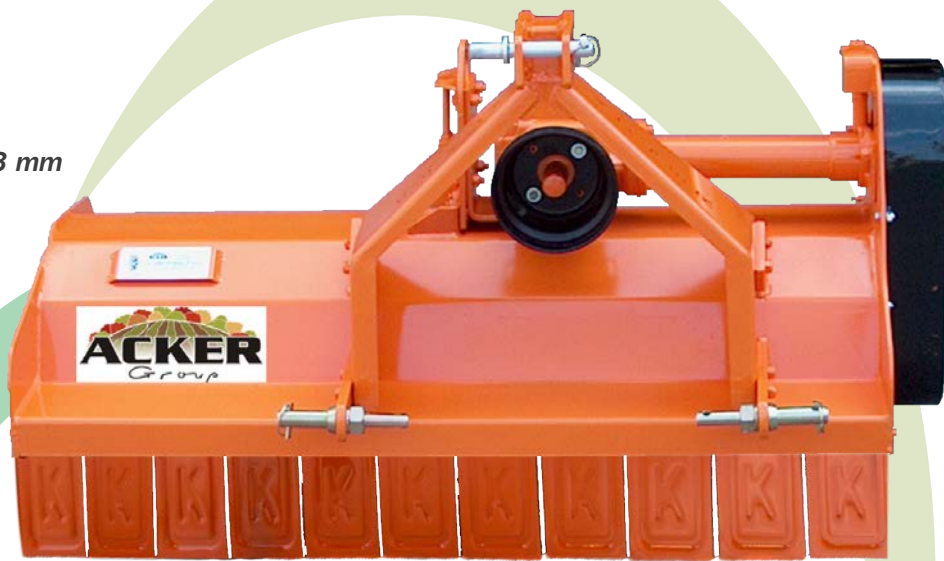

TYPE	WORKING WIDTH	TOTAL WIDTH	TRACTOR HORSEPOWER	HAMMERS	WEIGHT
	mm	mm	H.P.	LS	kg
KTS-LD 80	800	950	16-18	12	275
KTS-LD 100	1000	1150	20-22	16	305
KTS-LD 125	1250	1400	22-25	24	335
KTS-LD 150	1500	1650	25-30	28	370
KTS-LD 175	1750	1900	40-45	32	400
KTS-LD 200	2000	2150	45-50	36	430

STANDARD EQUIPMENT

- Motion transmission with 3 belts
- Comer gearbox, type T-311 (with rolip)
- Cardan shaft included

Shredder KTS LDM

Light-weighted agricultural shredder, with hydraulic movement, LS hammers (75mm). For tractors up to 60 H.P.



Hammer type

STRAIGHT



LS 75mm

Rotor diameter 133 mm
P.T.O. 540

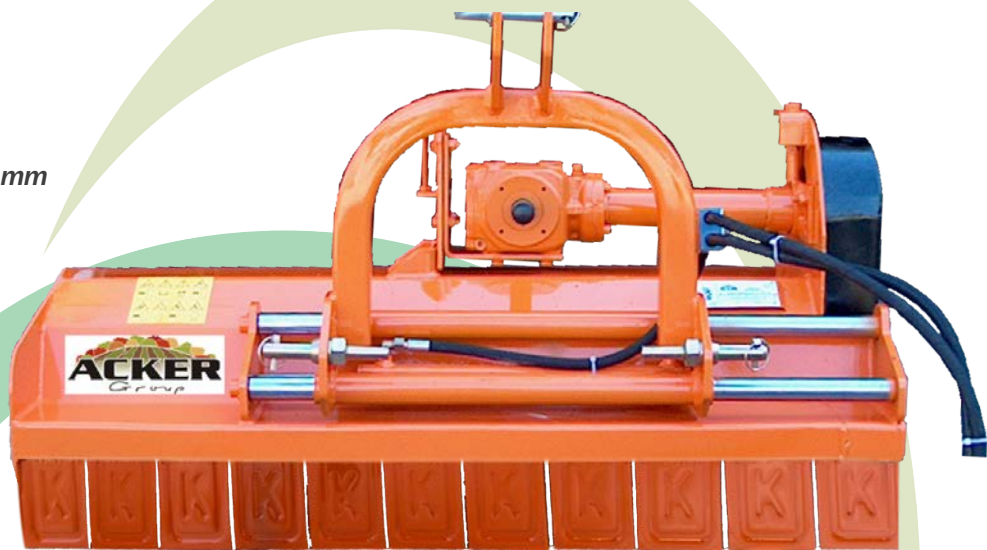

TYPE	WORKING WIDTH	TOTAL WIDTH	TRACTOR HORSEPOWER	HAMMERS	WEIGHT
	mm	mm	H.P.	LS	kg
KTS-LDM 125	1250	1400	25-30	24	335
KTS-LDM 150	1500	1650	35-40	28	370
KTS-LDM 175	1750	1900	40-45	32	400
KTS-LDM 200	2000	2150	45-50	36	430

STANDARD EQUIPMENT

- Motion transmission with 3 belts
- Comer gearbox, type T-311 (with rolip)
- Hydraulic side shift cylinder
- Cardan shaft included

Shredder KTS LDMR

Light-weighted agricultural shredder, with hydraulic movement and LS hammers (75mm). Suitable for vineyards. For tractors up to 60 H.P.

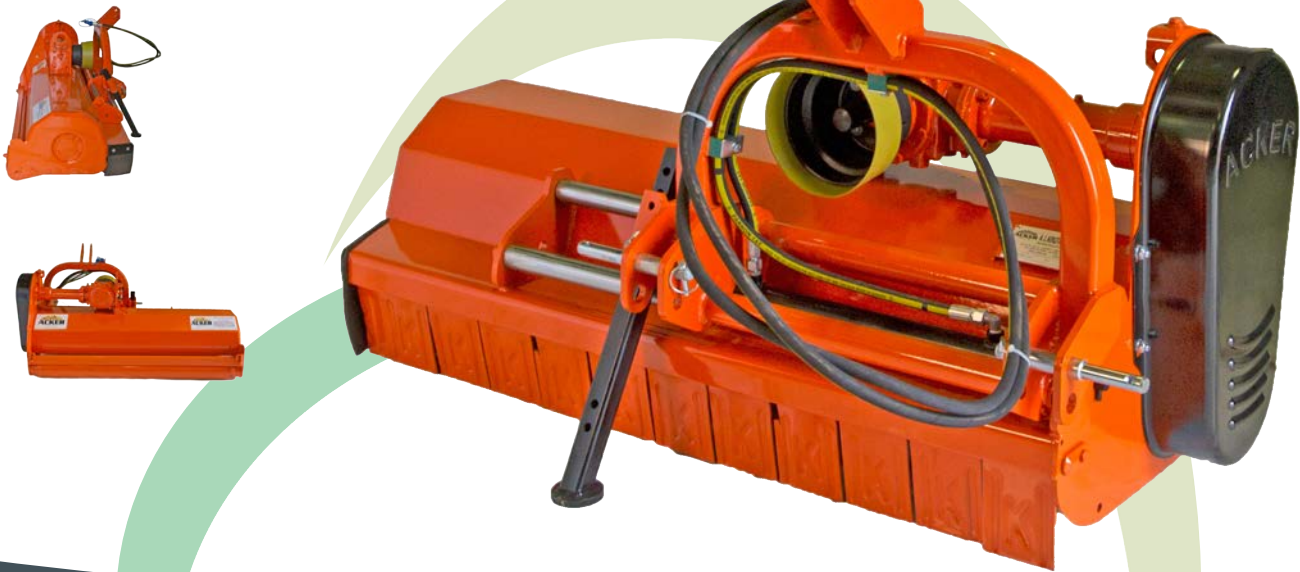

TYPE	WORKING WIDTH	TOTAL WIDTH	TRACTOR HORSEPOWER	HAMMERS	WEIGHT
	mm	mm	H.P.	LS	kg
KTS-LDMR 125	1250	1400	25-30	24	335
KTS-LDMR 150	1500	1650	35-40	28	370
KTS-LDMR 175	1750	1900	40-45	32	400
KTS-LDMR 200	2000	2150	45-50	36	430

STANDARD EQUIPMENT

- Motion transmission with 3 belts
- Hydraulic side shift cylinder
- Comer gearbox, type T-311 reducer (with rolip)
- Cardan shaft included

Hammer type

STRAIGHT



LS 75mm

Rotor diameter 133 mm
 P.T.O. 540

Shredder KTS V (LS)

Heavy-weighted agricultural shredder, with hydraulic movement and LS hammers (75mm).
 For tractors up to 100 H.P.

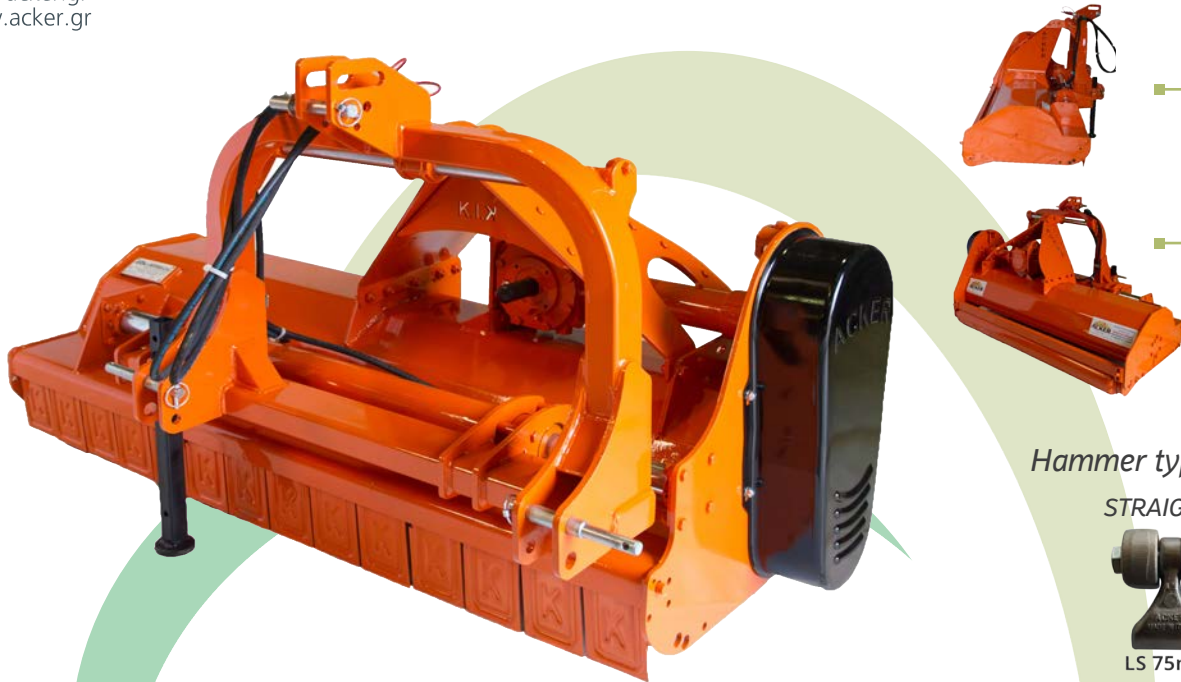

Hammer type

STRAIGHT



LS 75mm

Rotor diameter 160 mm
 P.T.O. 540 ή 1000

TYPE	WORKING WIDTH	TOTAL WIDTH	TRACTOR HORSEPOWER	HAMMERS	WEIGHT
	mm	mm	H.P.	LS Z	kg
KTS-V (LS) 125	1250	1400	25-30	24 48	480
KTS-V (LS) 135	1350	1500	30-40	24 48	520
KTS-V (LS) 150	1500	1650	40-50	24 60	580
KTS-V (LS) 162	1620	1750	50-60	24 60	630
KTS-V (LS) 175	1750	1900	60-70	28 72	660
KTS-V (LS) 200	2000	2150	70-80	32 84	750
KTS-V (LS) 225	2250	2400	80-90	36 96	840

STANDARD EQUIPMENT

- Motion transmission with 4 or 5 belts
- Comer gearbox, type T-312 (with rolip)
- Cardan shaft included

ADDITIONAL EQUIPMENT ON REQUEST

- Support wheels Ø190mm
- Hydraulic side shift cylinder
- Provision for the installation of a side wheel (top)
- Side wheel (top) (+ 500 mm width of cultivation)
- Front - rear suspension
- Support pedals
- Dust tire
- Branch collection rods

Shredder KTS V (NS)

Heavy-weighted agricultural shredder, with hydraulic movement and NS hammers (155mm). For tractors up to 100 H.P.



Hammer Type

STRAIGHT



NS 155mm

Rotor diameter 160 mm
 P.T.O. 540 or 1000



TYPE	WORKING WIDTH	TOTAL WIDTH	TRACTOR HORSEPOWER	HAMMERS		WEIGHT
	mm	mm	H.P.	NS	DZ	kg
KTS-V (NS) 125	1250	1400	25-30	10	40	480
KTS-V (NS) 135	1350	1500	30-40	10	40	520
KTS-V (NS) 150	1500	1650	40-50	12	48	580
KTS-V (NS) 162	1620	1750	50-60	12	48	630
KTS-V (NS) 175	1750	1900	60-70	16	56	660
KTS-V (NS) 200	2000	2150	70-80	16	64	750
KTS-V (NS) 225	2250	2400	80-90	20	72	840

STANDARD EQUIPMENT

- Motion transmission with 4 or 5 belts
- Comer gearbox, type T-312 (with rolip)
- Cardan shaft included

ADDITIONAL EQUIPMENT UPON REQUEST

- Support wheels Ø190mm
- Hydraulic side shift cylinder
- Provision for the installation of a side wheel (top)
- Side wheel (top) (+ 500 mm width of cultivation)
- Front - rear suspension
- Support pedals
- Dust tire
- Branch collection rods

Shredder KTS F(LS)

Fixed, heavy-weighted agricultural shredder, with LS hammers (75mm). For tractors up to 100 H.P.



Hammer type

STRAIGHT



LS 75mm

**Rotor diameter 160 mm
 P.T.O. 540 ή 1000**

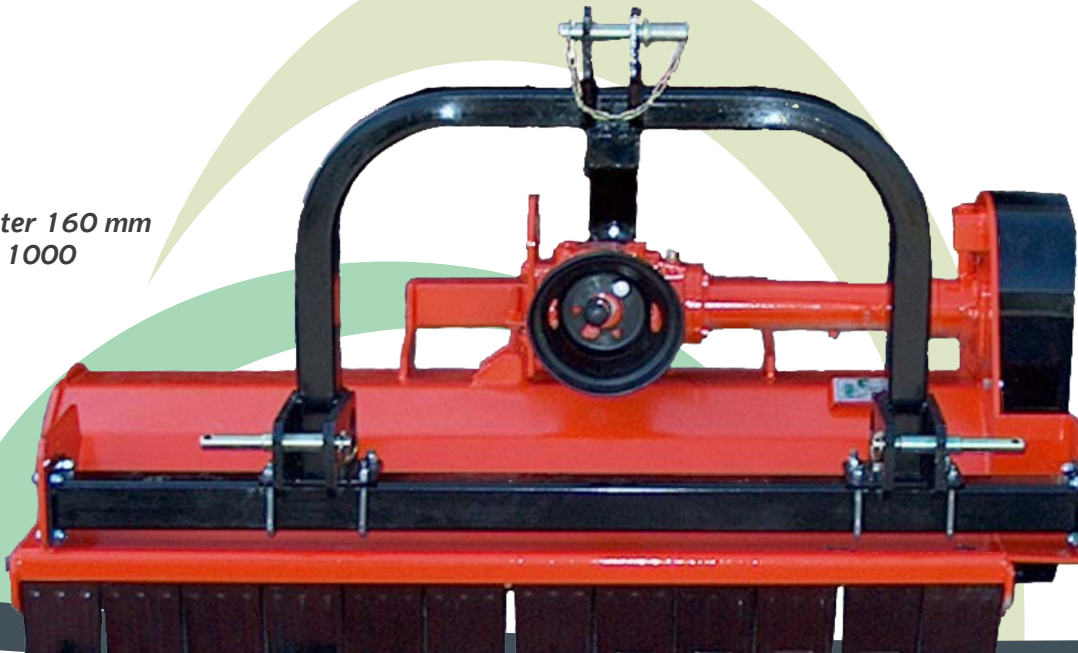

TYPE	WORKING WIDTH	TOTAL WIDTH	TRACTOR HORSEPOWER	HAMMERS	WEIGHT
	mm	mm	H.P.	LS	kg
KTS-F (LS) 125	1250	1400	25-30	24	480
KTS-F (LS) 135	1350	1500	30-40	24	520
KTS-F (LS) 150	1500	1650	40-50	24	580
KTS-F (LS) 162	1620	1750	50-60	24	630
KTS-F (LS) 175	1750	1900	60-70	28	660
KTS-F (LS) 200	2000	2150	70-80	62	750
KTS-F (LS) 225	2250	2400	80-90	36	840

STANDARD EQUIPMENT

- Motion transmission with 4 or 5 belts
- Comer gearbox, type T-312 (with rolip)
- Cardan shaft included

ADDITIONAL EQUIPMENT UPON REQUEST

- Support wheels Ø190mm
- Provision for the installation of a side wheel (top)
- Side wheel (top) (+ 500 mm width of cultivation)
- Front - rear suspension
- Support pedals
- Dust tire
- Branch collection rods

Shredder KTS F(NS)

Fixed, heavy-weighted agricultural shredder, with NS hammers (155mm). For tractors up to 100 H.P.



Hammer Type

STRAIGHT



Rotor diameter 160 mm
 P.T.O. 540 or 1000



TYPE	WORKING WIDTH	TOTAL WIDTH	TRACTOR HORSEPOWER	HAMMERS	WEIGHT
	mm	mm	H.P.	NS	kg
KTS-F (NS) 125	1250	1400	25-30	10	480
KTS-F (NS) 135	1350	1500	30-40	10	520
KTS-F (NS) 150	1500	1650	40-50	12	580
KTS-F (NS) 162	1620	1750	50-60	12	630
KTS-F (NS) 175	1750	1900	60-70	16	660
KTS-F (NS) 200	2000	2150	70-80	16	750
KTS-F (NS) 225	2250	2400	80-90	20	840

STANDARD EQUIPMENT

- Motion transmission with 4 or 5 belts
- Comer gearbox, type T-312 (with rolip)
- Cardan shaft included

ADDITIONAL EQUIPMENT UPON REQUEST

- Support wheels Ø190mm
- Provision for the installation of a side wheel (top)
- Side wheel (top) (+ 500 mm width of cultivation)
- Front - rear suspension
- Support pedals
- Dust tire
- Branch collection rods

Shredder KTS VN (LS)

Super heavy-weighted agricultural shredder, with hydraulic movement and LS hammers (75mm). For tractors up to 120 H.P.

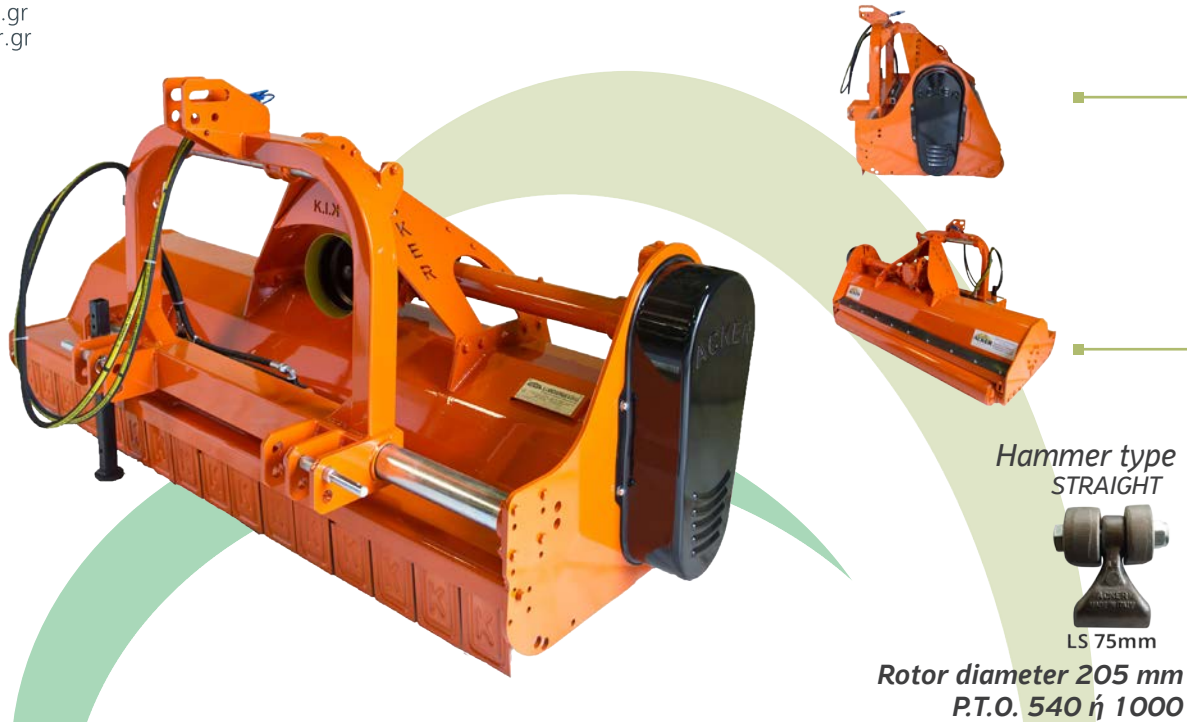

TYPE	WORKING WIDTH	TOTAL WIDTH	TRACTOR HORSEPOWER	HAMMERS		WEIGHT
	mm	mm	H.P.	LS	Z	kg
KTS-VN (LS) 125	1250	1400	25-30	20	48	500
KTS-VN (LS) 135	1350	1500	30-40	20	48	550
KTS-VN (LS) 150	1500	1650	40-50	24	60	620
KTS-VN (LS) 162	1620	1750	50-60	24	60	670
KTS-VN (LS) 175	1750	1900	60-70	28	72	745
KTS-VN (LS) 200	2000	2150	70-80	32	84	805
KTS-VN (LS) 225	2250	2400	80-90	36	96	880
KTS-VN (LS) 250	2500	2650	90-100	40	108	950
KTS-VN (LS) 275	2750	2900	100-110	44	120	1050
KTS-VN (LS) 300	3000	3150	110-120	48	132	1140

STANDARD EQUIPMENT

- Motion transmission with 4 or 5 belts
- Comer gearbox, type T-312 (with rolip)
- Cardan shaft included

ADDITIONAL EQUIPMENT UPON REQUEST

- Support wheels Ø190mm
- Hydraulic side shift cylinder
- Provision for the installation of a side wheel (top)
- Side wheel (top) (+ 500 mm width of cultivation)
- Front - rear suspension
- Support pedals
- Dust tire
- Branch collection rods

Shredder KTS VN (NS)

Super heavy-weighted agricultural shredder, with hydraulic movement and NS hammers (155mm). For tractors up to 120 H.P.



Hammer type
 STRAIGHT



Rotor diameter 205 mm
 P.T.O. 540 ή 1000

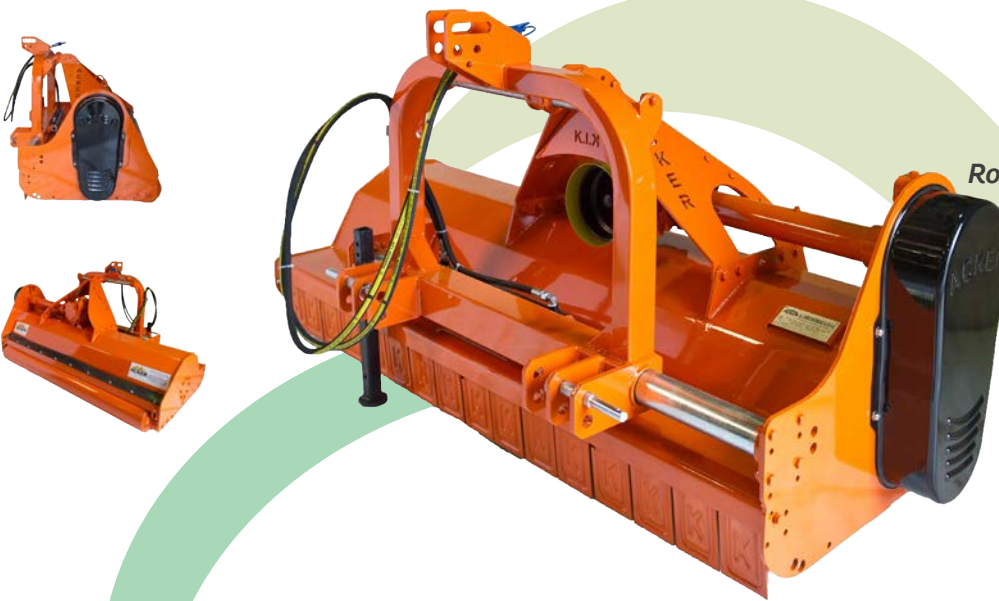

TYPE	WORKING WIDTH	TOTAL WIDTH	TRACTOR HORSEPOWER	HAMMERS		WEIGHT
	mm	mm	H.P.	NS	DZ	kg
KTS-VN (NS) 125	1250	1400	25-30	10	40	520
KTS-VN (NS) 135	1350	1500	30-40	10	40	570
KTS-VN (NS) 150	1500	1650	40-50	12	48	620
KTS-VN (NS) 162	1620	1750	50-60	12	48	670
KTS-VN (NS) 175	1750	1900	60-70	16	56	745
KTS-VN (NS) 200	2000	2150	70-80	16	64	805
KTS-VN (NS) 225	2250	2400	80-90	20	72	880
KTS-VN (NS) 250	2500	2650	90-100	20	80	950
KTS-VN (NS) 275	2750	2900	100-110	24	88	1050
KTS-VN (NS) 300	3000	3150	110-120	24	96	1140

STANDARD EQUIPMENT

- Motion transmission with 4 or 5 belts
- Comer gearbox, type T-312 (with rolip)
- Cardan shaft included

ADDITIONAL EQUIPMENT ON REQUEST

- Support wheels Ø190mm
- Hydraulic side shift cylinder
- Provision for the installation of a side wheel (top)
- Side wheel (top) (+ 500 mm width of cultivation)
- Front - rear suspension
- Support pedals
- Dust tire
- Branch collection rods

Shredder KTS FN(LS)

Fixed, super heavy-weighted agricultural shredder with LS hammers (75mm). For tractors up to 120 H.P.



Hammer type

STRAIGHT



LS 75mm

Rotor diameter 205 mm
 P.T.O. 540 ή 1000



TYPE	WORKING WIDTH	TOTAL WIDTH	TRACTOR HORSEPOWER	HAMMERS		WEIGHT
	mm	mm	H.P.	LS	Z	kg
KTS-FN (LS) 125	1250	1400	25-30	20	48	520
KTS-FN (LS) 135	1350	1500	30-40	20	48	570
KTS-FN (LS) 150	1500	1650	40-50	24	60	620
KTS-FN (LS) 162	1620	1750	50-60	24	60	670
KTS-FN (LS) 175	1750	1900	60-70	28	72	745
KTS-FN (LS) 200	2000	2150	70-80	32	84	805
KTS-FN (LS) 225	2250	2400	80-90	36	96	880
KTS-FN (LS) 250	2500	2650	90-100	40	108	950
KTS-FN (LS) 275	2750	2900	100-110	44	120	1050
KTS-FN (LS) 300	3000	3150	110-120	48	132	1140

STANDARD EQUIPMENT

- Motion transmission with 4 or 5 belts
- Comer gearbox, type T-312 (with rolip)
- Cardan shaft included

ADDITIONAL EQUIPMENT UPON REQUEST

- Support wheels Ø190mm
- Provision for the installation of a side wheel (top)
- Side wheel (top) (+ 500 mm width of cultivation)
- Front - rear suspension
- Support pedals
- Dust tire
- Branch collection rods

Shredder KTS FN(NS)

Fixed, super heavy-weighted agricultural shredder, with NS hammers (155mm). For tractors up to 120 H.P.



Hammer type

STRAIGHT



NS 155mm

Rotor diameter 205 mm
 P.T.O. 540 ή 1000

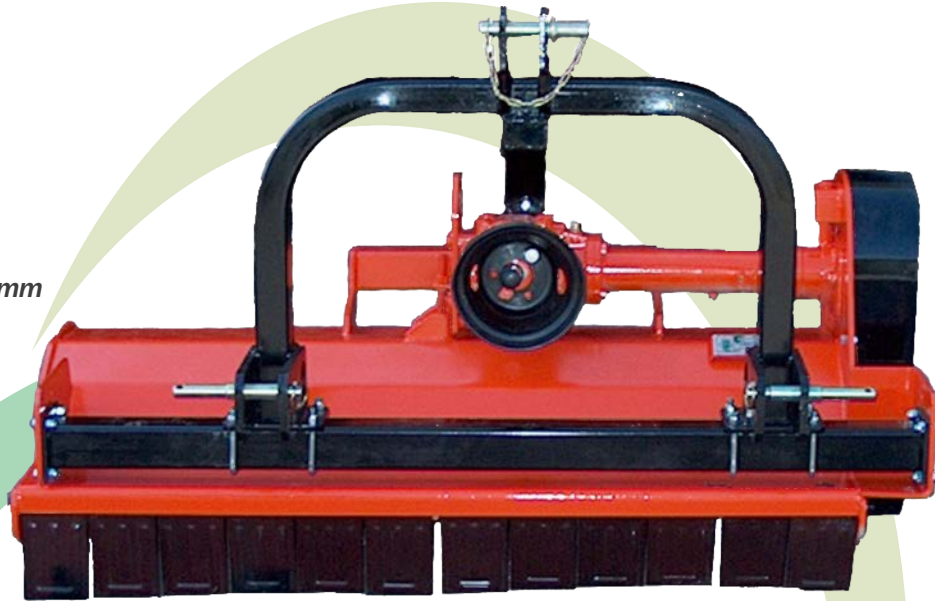

TYPE	WORKING WIDTH	TOTAL WIDTH	TRACTOR HORSEPOWER	HAMMERS		WEIGHT
	mm	mm	H.P.	NS	DZ	kg
KTS-FN (NS) 125	1250	1400	25-30	10	40	520
KTS-FN (NS) 135	1350	1500	30-40	10	40	570
KTS-FN (NS) 150	1500	1650	40-50	12	48	620
KTS-FN (NS) 162	1620	1750	50-60	12	48	670
KTS-FN (NS) 175	1750	1900	60-70	16	56	745
KTS-FN (NS) 200	2000	2150	70-80	16	64	805
KTS-FN (NS) 225	2250	2400	80-90	20	72	880
KTS-FN (NS) 250	2500	2650	90-100	20	80	950
KTS-FN (NS) 275	2750	2900	100-110	24	88	1050
KTS-FN (NS) 300	3000	3150	110-120	24	96	1140

STANDARD EQUIPMENT

- Motion transmission with 4 or 5 belts
- Comer gearbox, type T-312 (with rolip)
- Cardan shaft included

ADDITIONAL EQUIPMENT UPON REQUEST

- Support wheels Ø190mm
- Provision for the installation of a side wheel (top)
- Side wheel (top) (+ 500 mm width of cultivation)
- Front - rear suspension
- Support pedals
- Dust tire
- Branch collection rods

Shredder KTS - MX

Super heavy-weighted agricultural shredder, for open cultivations (cotton, maize, etc.). For tractors up to 120 H.P.



Hammer Type
BLADES



Rotor diameter 205 or 219 mm
P.T.O. 540 ή 1000

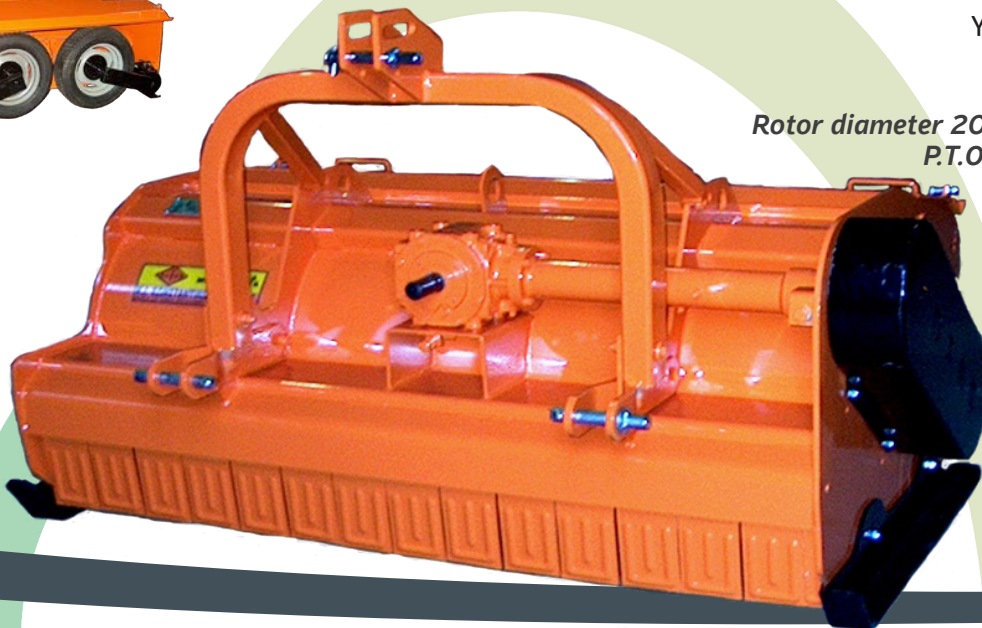

ΤΥΠΟΣ	WORKING WIDTH	TOTAL WIDTH	TRACTOR HORSEPOWER	BLADES	WEIGHT
	mm	mm	H.P.	Y	kg
KTS-MX 175	1750	1970	60-70	48	740
KTS-MX 200	2000	2220	70-80	48	800
KTS-MX 225	2250	2470	80-90	60	945

EXTRA REINFORCED

KTS-MX 250	2500	2720	80-100	60	1050
KTS-MX 275	2750	2970	95-105	72	1160
KTS-MX 300	3000	3220	95-108	80	1270
KTS-MX 310	3100	3320	95-110	84	1320
KTS-MX 320	3200	3420	95-110	84	1370

STANDARD EQUIPMENT

- Comer gearbox, type T-312 with rolip or T-290 with rolip
- Initial blade installation (Y)
- Cardan shaft included
- Elastic Wheels
- Support pedals

Shredder KTS VN-P

Super heavy-weighted agricultural shredder with rear door and LS hammers (75mm). For tractors up to 120 H.P.



Hammer type

STRAIGHT



LS 75mm

Rotor diameter 205 mm
 P.T.O. 540 ή 1000

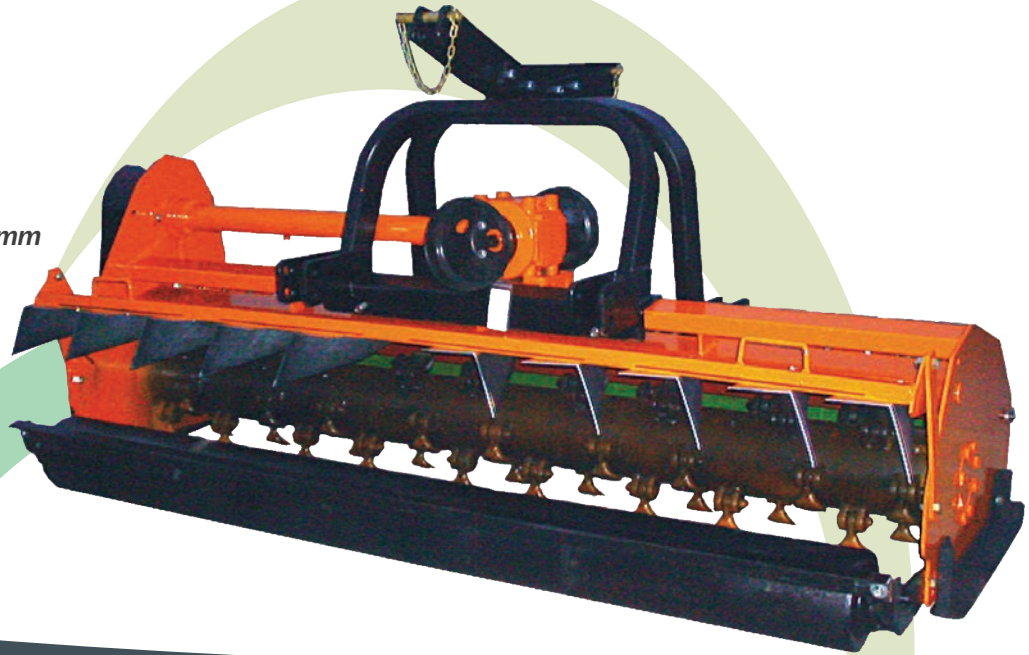

TYPE	WORKING WIDTH	TOTAL WIDTH	TRACTOR HORSEPOWER	HAMMERS & BLADES	WEIGHT
	mm	mm	H.P.	ZS-NS-DZ/Z LS	kg
KTS VN-P 150	1500	1650	40-50	12/42 30	610
KTS VN-P 162	1620	1775	50-60	13/42 30	660
KTS VN-P 175	1750	1900	60-70	14/48 36	714
KTS VN-P 200	2000	2150	70-80	16/54 42	816
KTS VN-P 225	2250	2400	80-90	18/60 48	918
KTS VN-P 250	2500	2650	90-100	20/66 54	1020
KTS VN-P 280	2800	2950	100-110	22/72 60	1140
KTS VN-P 300	3000	3150	110-120	24/78 66	1220

STANDARD EQUIPMENT

- Comer gearbox, type T-312 (with rolip) or T-290 (µε rolip)
- Motion transmission with 4/5 belts
- Initial installation of straight-cut hammers (NS)
- Support pedals
- Cardan shaft included

ADDITIONAL EQUIPMENT UPON REQUEST

- Front - rear suspension

Shredder KTS-V SP

Heavy-weighted agricultural shredder for removing plant residues from greenhouse crops. For tractors up to 100 H.P.



TYPE	WORKING WIDTH	TOTAL WIDTH	TRACTOR HORSEPOWER	HAMMERS	WEIGHT
	mm	mm	H.P.	kg	kg
KTS-V SP 125	1250	1400	25-30	24	500
KTS-V SP 135	1350	1500	30-40	24	540
KTS-V SP 150	1500	1650	40-50	24	600
KTS-V SP 162	1620	1750	50-60	24	650
KTS-V SP 175	1750	1900	60-70	28	680
KTS VN-P 200	2000	2150	70-80	32	700

STANDARD EQUIPMENT

- Cardan shaft included
- Comer gearbox, type T-312 (with rolip)
- Door for easy cleaning
- Special protection of the bearings from the melting of the twines

ADDITIONAL EQUIPMENT UPON REQUEST

- Hydraulic side shift cylinder

Shredder KTS AP-L

Light-weighted agricultural shredder, tilting, rotating, with LS hammers (75mm). Suitable for working on slopes and terraces. For tractors up to 90 H.P.



Hammer type

STRAIGHT



LS 75mm

Rotor diameter 133 mm

P.T.O. 540



TYPE	TRACTOR HORSEPOWER	WORKING WIDTH	TOTAL WIDTH	WEIGHT
	H.P.	mm	mm	kg
KTS AP L TILTABLE 135	60	1350	1500	500
KTS AP L TILTABLE 150	70	1500	1650	530
KTS AP L TILTABLE 162	80	1620	1750	555
KTS AP L TILTABLE 175	85	1750	1900	580

STANDARD EQUIPMENT

- Comer gearbox, type T-311 (with rolip)
- Cardan shaft included

Shredder KTS AP-V

Heavy-weighted agricultural shredder, tilting and rotating, with NS hammers (155mm) or LS hammers (75mm). Suitable for working on slopes and terraces. For tractors up to 110 H.P.



Hammer Type

STRAIGHT



Rotor diameter 160 mm
P.T.O. 540 ή 1000



TYPE	TRACTOR HORSEPOWER	WORKING WIDTH	TOTAL WIDTH	WEIGHT
	H.P.	mm	mm	kg
KTS AP V TILTABLE 150	80	1500	1650	675
KTS AP V TILTABLE 162	85	1620	1750	710
KTS AP V TILTABLE 175	90	1750	1900	750
KTS AP V TILTABLE 200	100	2000	2150	815
KTS AP V TILTABLE 225	110	2250	2400	890

STANDARD EQUIPMENT

- Comer gearbox, type T-312 (with rolip)
- Cardan shaft included

Shredder KTS AP-VN

Super heavy-weighted agricultural shredder, tilting and rotating, with LS hammers (75mm) or NS hammers (155mm). Suitable for working on slopes and terraces. For tractors up to 120 H.P.



Hammer type

STRAIGHT



Rotor diameter 205 mm
P.T.O. 540 ή 1000

TYPE	TRACTOR HORSEPOWER	WORKING WIDTH	TOTAL WIDTH	WEIGHT
	H.P.	mm	mm	kg
KTS AP VN TILTABLE 150	85	1500	1650	780
KTS AP VN TILTABLE 162	90	1620	1750	840
KTS AP VN TILTABLE 175	100	1750	1900	940
KTS AP VN TILTABLE 200	110	2000	2150	1035
KTS AP VN TILTABLE 225	120	2250	2400	1140

STANDARD EQUIPMENT

- Comer gearbox, type T-312 (with rolip)
- Cardan shaft included

Shredder KTS V(N) S

Super heavy-weighted agricultural shredder, tilting and sliding, with LS hammers (75mm). Suitable for working on slopes and terraces. For tractors up to 120 H.P.



Hammer type

STRAIGHT



LS 75mm

Rotor diameter 205 mm

P.T.O. 1000

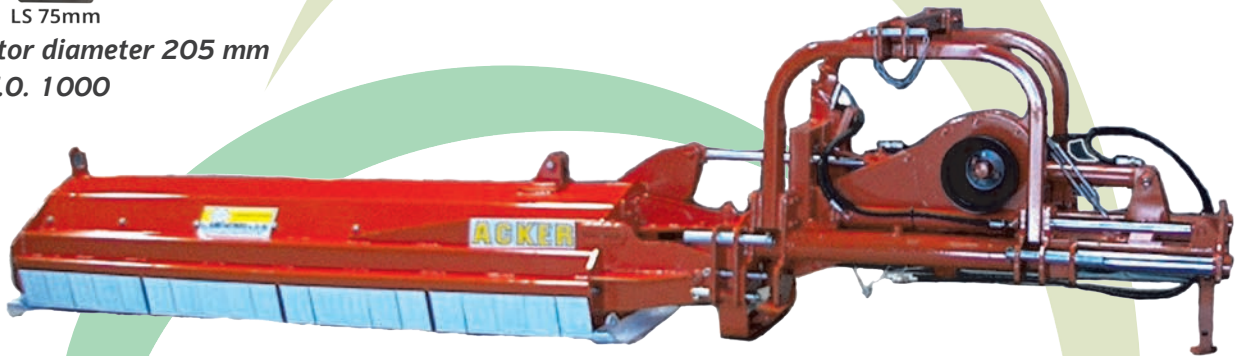

TYPE	WORKING WIDTH	TOTAL WIDTH	TRACTOR HORSEPOWER	HAMMERS	WEIGHT
	mm	mm	H.P.	LS	kg
KTS-V(N) S-135	1350	3750	40-50	24	880
KTS-V(N) S-150	1500	3850	50-60	24	950
KTS-V(N) S-162	1620	4000	60-70	28	1020
KTS-V(N) S-175	1750	4250	70-80	32	1100
KTS-V(N) S-200	2000	4500	80-90	36	1180
KTS-V(N) S-225	2250	4750	90-100	40	1250

STANDARD EQUIPMENT

- Comer gearbox, type T-312 (with rolip)
- Cardan shaft included

Shredder KTS V(N) S

Sindos Industrial Area 4-A7
ZIP Code 57022, Thessaloniki
T: +30 2310 79.79.84 -85
T: +30 2310 79.99.88
F: +30 2310 79.96.27
info@acker.gr
www.acker.gr



90° Up To -60°

60°

25cm | 25cm

Width Of Cultivation
50cm

Potato cultivator KE-155 (2rows)

Agricultural cultivator with 2 rows, suitable for the creation of dikes and soil cutting in-between dikes in the cultivation of potatoes.



TYPE	WORKING WIDTH	TRACTOR HORSEPOWER	NUMBER OF BLADES	WEIGHT
	mm	H.P.		kg
KE-155/2RF	155	70	32	800

Potato cultivator KE-155 (2rows)

Sindos Industrial Area 4-A7
 ZIP Code 57022, Thessaloniki
 T: +30 2310 79.79.84 -85
 T: +30 2310 79.99.88
 F: +30 2310 79.96.27
 info@acker.gr
 www.acker.gr

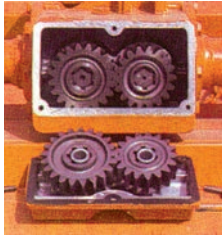

**COMER GEARBOX
 MZ-4A**

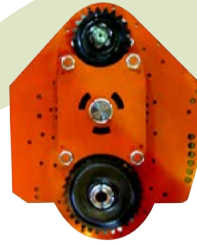

GEAR DRIVE

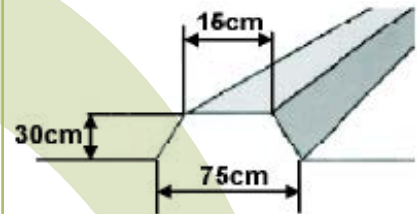

**INDICATIVE DYKE
 DIMENSIONS**

TYPE	REDUCER	P.T.O.	REDUCER GEAR	ROTATIONS
		U/min	Z	U/min
KE-155	MZ-4A	1000	23/18	285
KE-155	MZ-4A	1000	21/19	329
KE-155	MZ-4A	1000	19/21	398
KE-155	MZ-4A	1000	18/23	459

Potato cultivator KHY-305 (4rows)

Agricultural cultivator with 4 rows, suitable for the creation of dikes and soil cutting in-between dikes in the cultivation of potatoes.

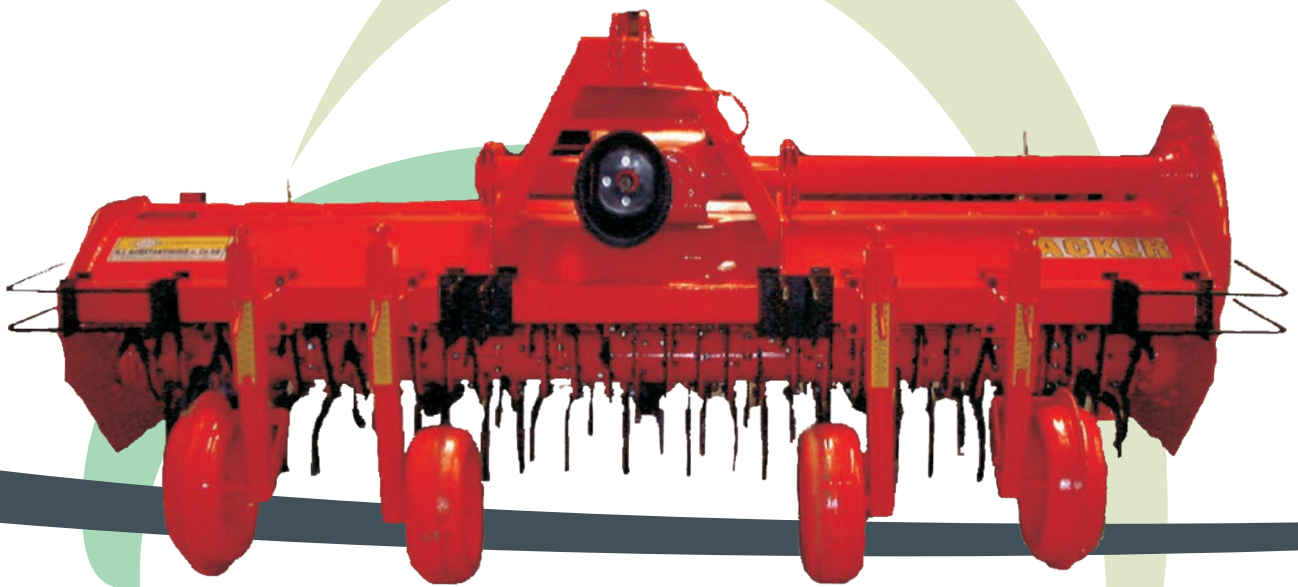

TYPE	WORKING WIDTH	TRACTOR HORSEPOWER	NUMBER OF BLADES	WEIGHT
	mm	H.P.		kg
KHZ-315/4RF	3100	90	64	1620



Potato cultivator KHY-305 (4rows)

Sindos Industrial Area 4-A7
ZIP Code 57022, Thessaloniki
T: +30 2310 79.79.84 -85
T: +30 2310 79.99.88
F: +30 2310 79.96.27
info@acker.gr
www.acker.gr



GEAR DRIVE

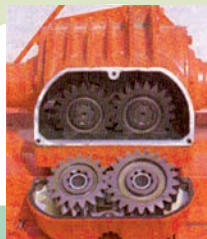

**COMER GEARBOX,
TYPE MZ-3A**

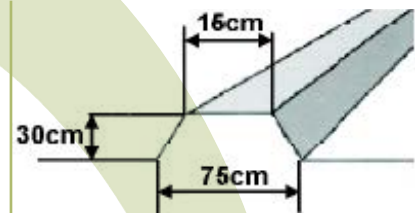

**INDICATIVE
DYKE
DIMENSIONS**

TYPE	REDUCER	P.T.O.	REDUCER GEARS	ROTATIONS
		U/min	Z	U/min
KHY-315	MZ-3A	1000	21/17	295
KHY-315	MZ-3A	1000	20/19	346
KHY-315	MZ-3A	1000	19/20	384
KHY-315	MZ-3A	1000	17/21	450

Salad cultivator BF-S

Agricultural cultivator suitable for the creation of dikes for the cultivation of vegetables (cabbage, lettuce, leek, cauliflower, etc.).



For an intensive - sowing a growth - simulating soil. With the ACKER salad cultivator this result is possible:

1. The rotary grinder breaks up the soil, without compressing the ground.
2. The running after - friable - roll crumbles the top soil and produces an optimum structure of surface. The friable - roll works against the direction of rotation of the rotary grinder.
3. The feeding disks lead the ground exactly into the rotary grinder. An accurate boundary of your bed is the result. The feeding disks are widely and vertically adjustable.



TYPE	WORKING WIDTH	TRACTOR HORSE-POWER	WEIGHT
	mm	H.P.	kg
BF-S 140	140	40-70	800
BF-S 170	170	50-80	900
BF-S 185	185	60-90	950

Salad cultivator BF-S

Sindos Industrial Area 4-A7
 ZIP Code 57022, Thessaloniki
 T: +30 2310 79.79.84 -85
 T: +30 2310 79.99.88
 F: +30 2310 79.96.27
 info@acker.gr
 www.acker.gr

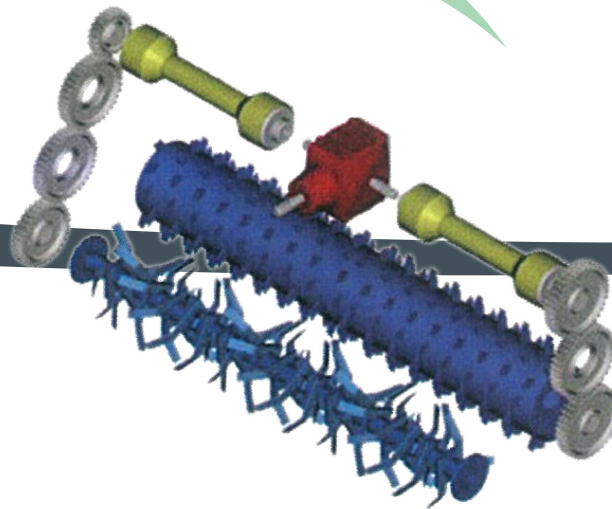
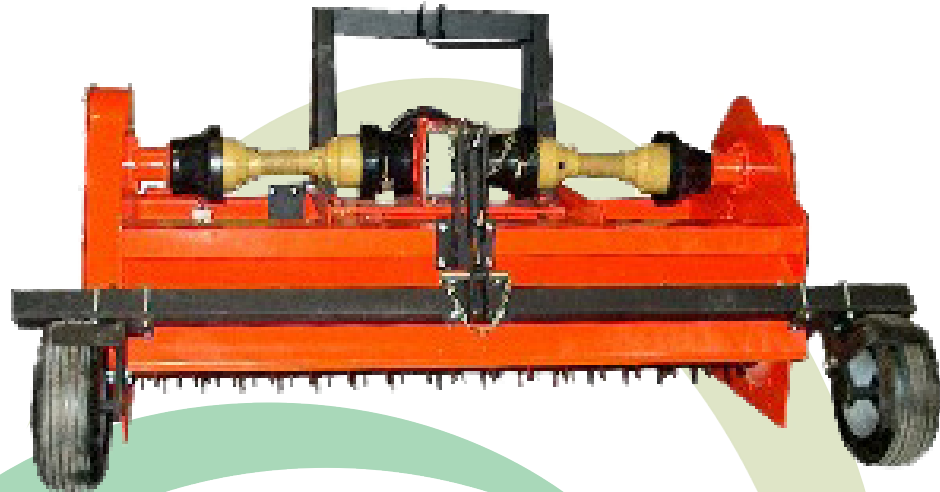

← driving direction

With a single operation we can achieve the following desired results- advantages:

1. A good water level on the soil.
2. Enough humidity on the root.
3. An early growth of the plant.



Reverse bed cultivator BF-U

Agricultural cultivator suitable for the creation of dikes for the cultivation of vegetables (cabbage, lettuce, leek, cauliflower, etc.), when the soil is full with stones.



For intensive vegetable cultivation is needed a growth - enhancing soil. With ACKER reverse bed cultivator you will reach this result:

1. The rotary grinder breaks up the soil, without compressing it too hard.
2. The bars behind the rotor separate the crushed soil from stones. The stones fall vertically downwards on the grid and are covered with soil. The result is a largely stonefree soil layer.
3. The feeding disks lead the ground exactly into the rotary grinder. An accurate boundary of your bed is the result. The feeding disks are widely and vertically adjustable.



TYPE	WORKING WIDTH	POWER REQUIREMENT	WEIGHT
	cm	P.S.	kg
BF-U 140	140	50-65	1150
BF-U 150	150	65-75	1200
BF-U 180	180	80-120	1350
BF-U 255	255	90-130	1650

Reverse bed cultivator BF-U

Sindos Industrial Area 4-A7
 ZIP Code 57022, Thessaloniki
 T: +30 2310 79.79.84 -85
 T: +30 2310 79.99.88
 F: +30 2310 79.96.27
 info@acker.gr
 www.acker.gr

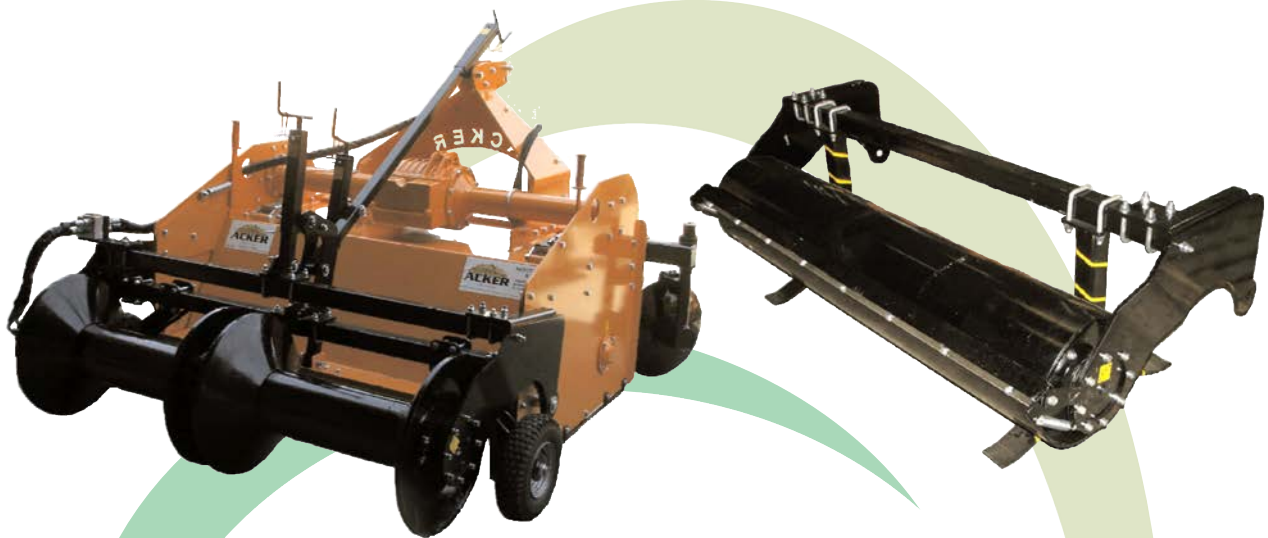

With a single operation we can achieve the following desired results- advantages:

1. A good water level on the soil.
2. Enough humidity on the root.
3. An early growth of the plant.
4. Nearly stonefree bed.

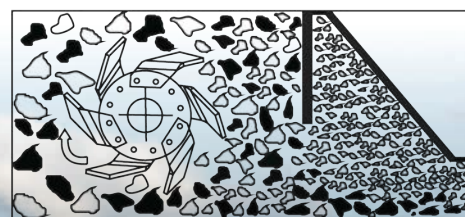

← driving direction



Rotary harrow ZKS-Y

Rotary harrow for tractors up to 200 H.P.
 P.T.O. 540 / 1000, with Ø 60 stub axle skew-angled roller bearings.

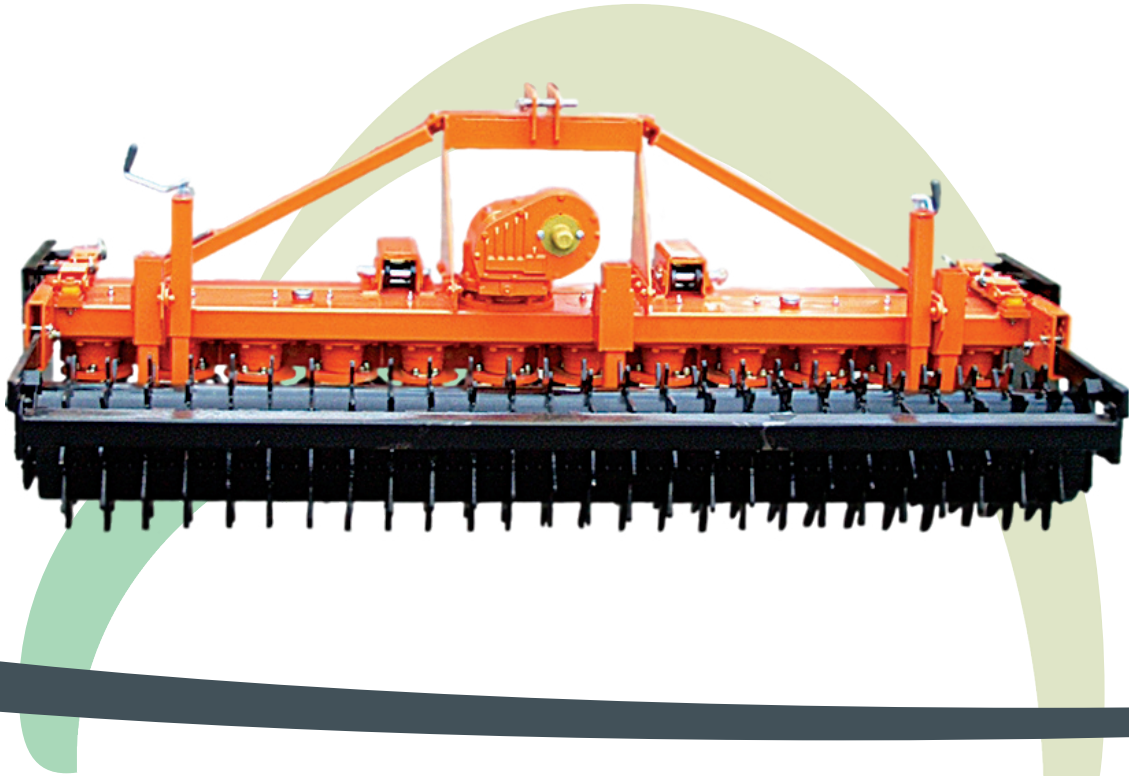

TYPE	WORKING WIDTH	TRACTOR HORSEPOWER	BLADES	WEIGHT
	mm	H.P.		kg
ZKS-200/MV814	200	55-70	16	1030
ZKS-250/MV819	250	70-90	20	1290
ZKS-300/MV819	300	90-110	24	1550
ZKS-350/MV819	350	110-130	28	1810

STANDARD EQUIPMENT

- Cardan shaft included
- Comer gearbox, type MV-819

ADDITIONAL EQUIPMENT UPON REQUEST

- Tire teeth
- Comer gearbox, type MV-824
- Comer gearbox, type DV-823 with 3 external speeds
- Second machine lifting device

Rotary harrow ZKS-Y

Sindos Industrial Area 4-A7
 ZIP Code 57022, Thessaloniki
 T: +30 2310 79.79.84 -85
 T: +30 2310 79.99.88
 F: +30 2310 79.96.27
 info@acker.gr
 www.acker.gr



COMER GEARBOX, TYPE DV-823, WITH 3 EXTERNAL SPEEDS



COMER GEARBOX, TYPE MV-824



*Closed rectangular pipe
 300x100x8*

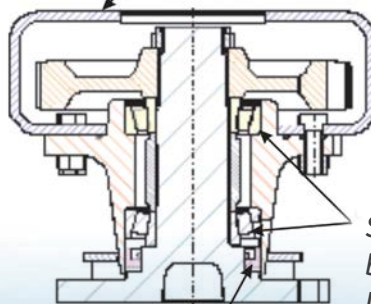

*Skew-angle roller bearing
 No. 32212*

*COMBI Seal
 85x110x16*

Rotary harrow ZKS-ASH

Segmented rotary harrow for tractors up to 260 H.P. P.T.O. 1000, with Ø 60 stub axle skew-angled roller bearings.



TYPE	WORKING WIDTH	TRACTOR HORSEPOWER	BLADES	WEIGHT
	mm	H.P.		kg
ZKS-ASH 400	400	160-200	32	2900
ZKS-ASH 450	450			
ZKS-ASH 500	500	200-250	40	3300
ZKS-ASH 550	550			
ZKS-ASH 600	600	250-280	48	3650

STANDARD EQUIPMENT

- 2 lateral reducers with gear shift capability
- Cardan shaft included

ADDITIONAL EQUIPMENT UPON REQUEST

- Tyre teeth
- Second machine lifting device



Rotary harrow ZKS-ASH

Sindos Industrial Area 4-A7
 ZIP Code 57022, Thessaloniki
 T: +30 2310 79.79.84 -85
 T: +30 2310 79.99.88
 F: +30 2310 79.96.27
 info@acker.gr
 www.acker.gr

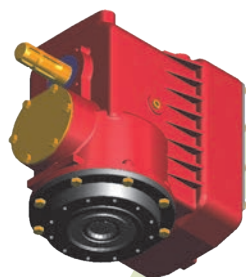

**COMER LATERAL REDUCERS,
 TYPE MV 817**

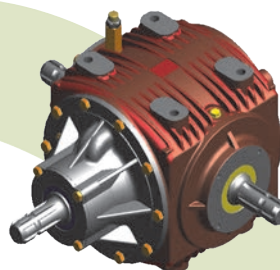

**COMER CENTRAL REDUCER,
 TYPE T-331**

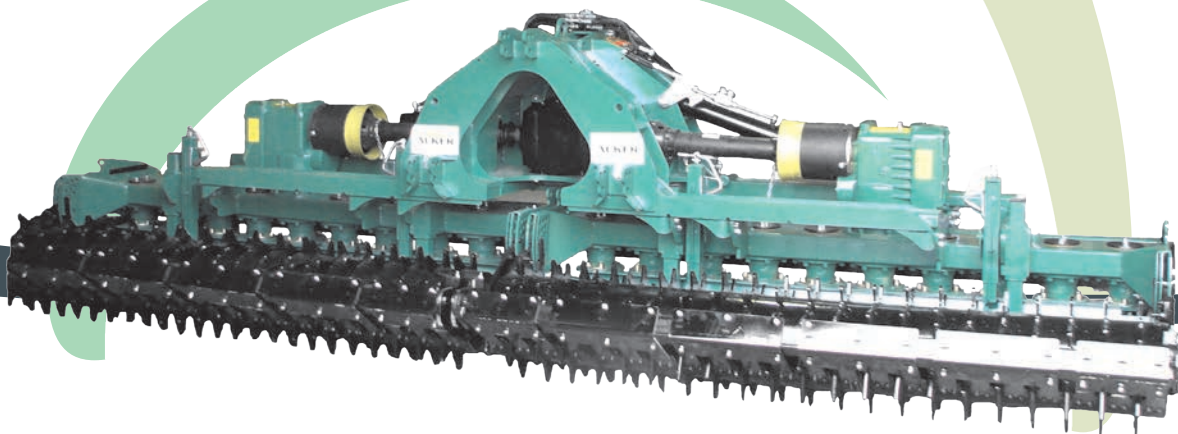

*Closed rectangular pipe
 300x100x8*

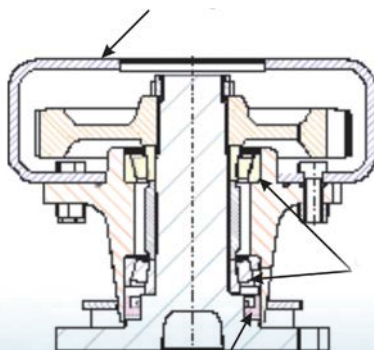

*Skew-angle roller
 bearing
 No. 32212*

*COMBI Seal
 85x110x16*

POLYDISC KON-DISK

Rigid-big dimensioned frame, independent rubber suspension, closed type bearings (SKF), disc diameter 510 mm, wide spectrum of working width. Suspension of three points.



TYPE	TRACTOR HORSEPOWER	WORKING WIDTH	HYDRAULIC SHIFT	DEPTH OF WORK
	H.P.	cm		cm
KON-DISK 200	60-80	200	-	20
KON-DISK 250	80-1100	250	-	20
KON-DISK 300	100-120	300	-	20
KON-DISK 350	120-160	350	-	20
KON-DISK 400	140-180	400	-/+	20
KON-DISK 450	150-240	450	+	20
KON-DISK 500	160-260	500	+	20
KON-DISK 550	180-280	550	+	20
KON-DISK 600	200-300	600	+	20

ADDITIONAL EQUIPMENT UPON REQUEST

- *Hydraulically folding from 4m width and beyond.*
- *Base for the placement of counterweights*
- *Weight – counterweight 45 kg/item*



POLYDISC KON-DISK

Sindos Industrial Area 4-A7
ZIP Code 57022, Thessaloniki
T: +30 2310 79.79.84 -85
T: +30 2310 79.99.88
F: +30 2310 79.96.27
info@acker.gr
www.acker.gr

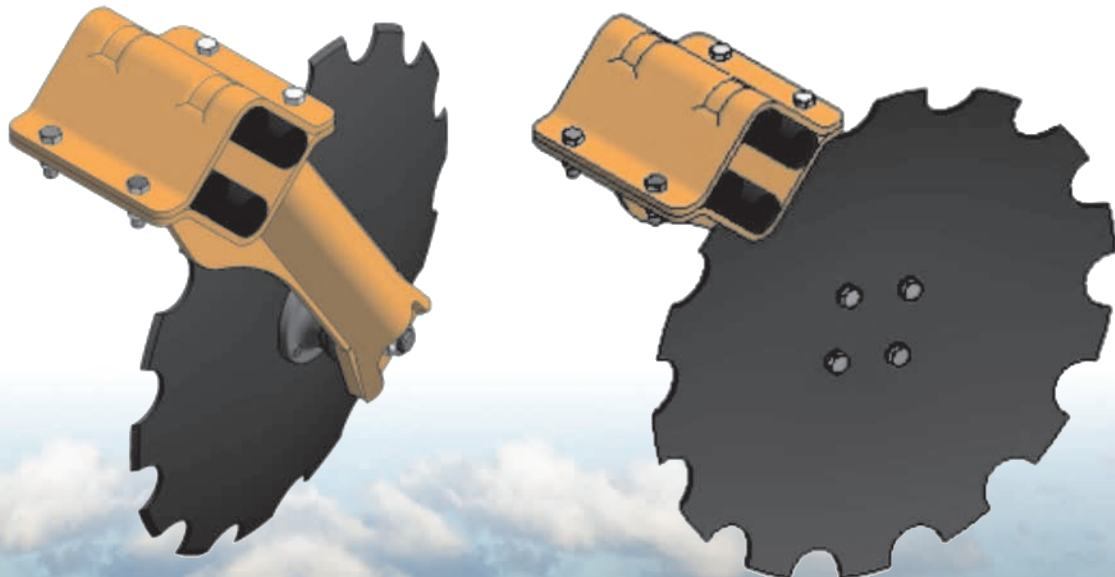

Multi-disc KON-DISK Folding

Folding multi-disc with rigid, big dimensioned frame, independent rubber suspension, closed type bearings (SKF), disc diameter 510 mm, wide spectrum of working width. Hydraulically folding from 4m width and beyond. Suspension of three points.

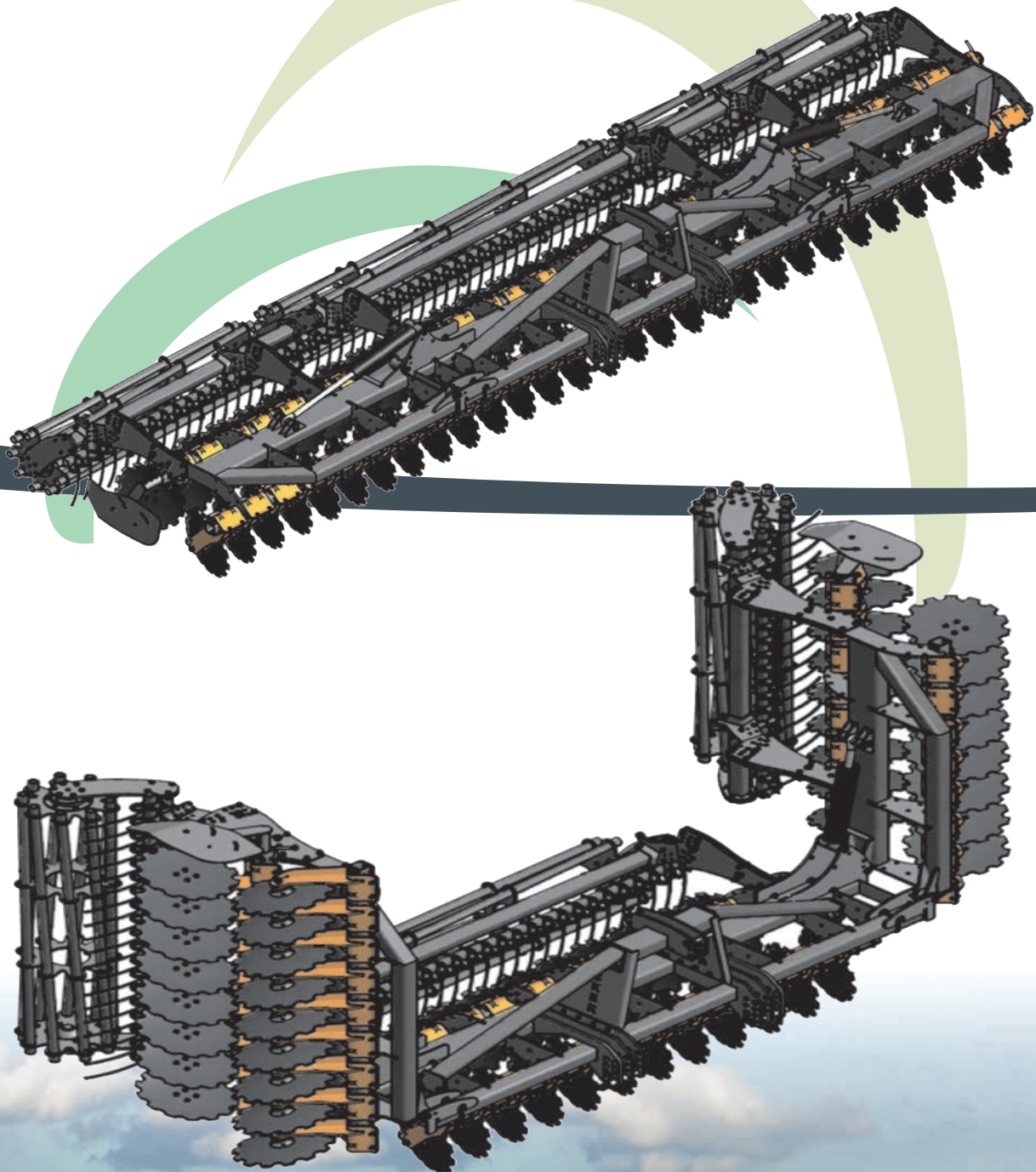

Multi-disc KON-DISK Folding

Sindos Industrial Area 4-A7
 ZIP Code 57022, Thessaloniki
 T: +30 2310 79.79.84 -85
 T: +30 2310 79.99.88
 F: +30 2310 79.96.27
 info@acker.gr
 www.acker.gr

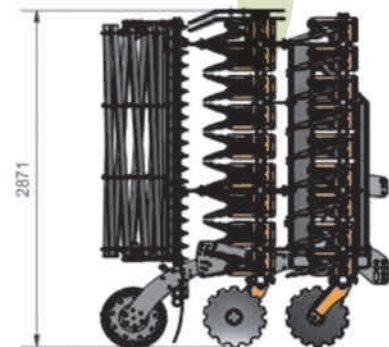
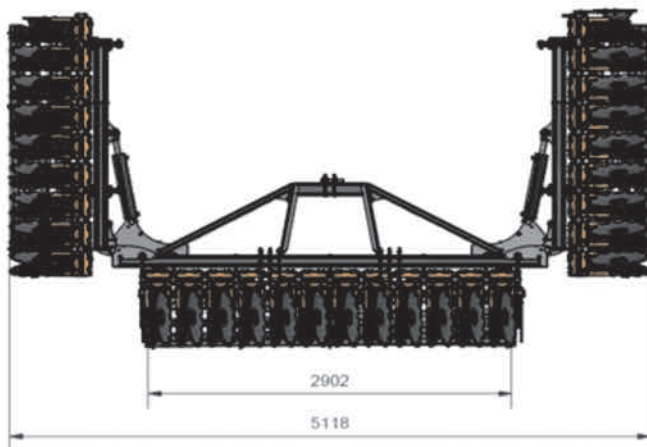
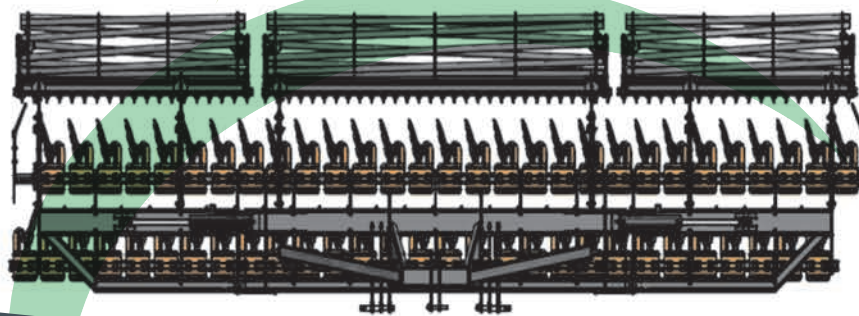
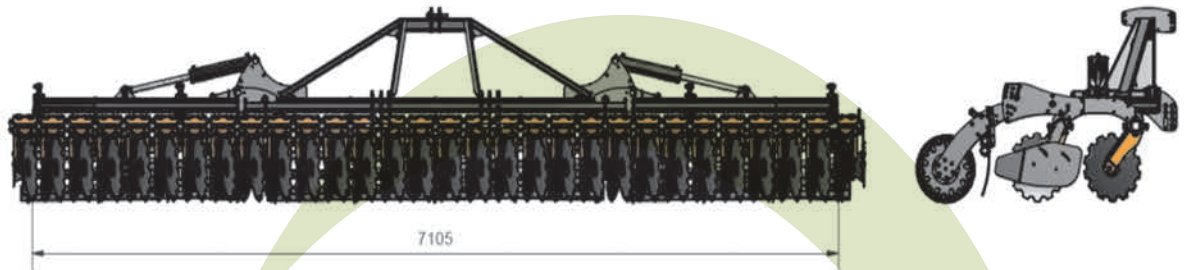

Multi-disc KON-DISK AS Folding-Hanging

Folding and hanging multi-disc with rigid, big dimensioned frame, independent rubber suspension, closed type bearings (SKF), disc diameter 510 mm, wide spectrum of working width. Hydraulically folding from 4m width and beyond. Suspension of three points.

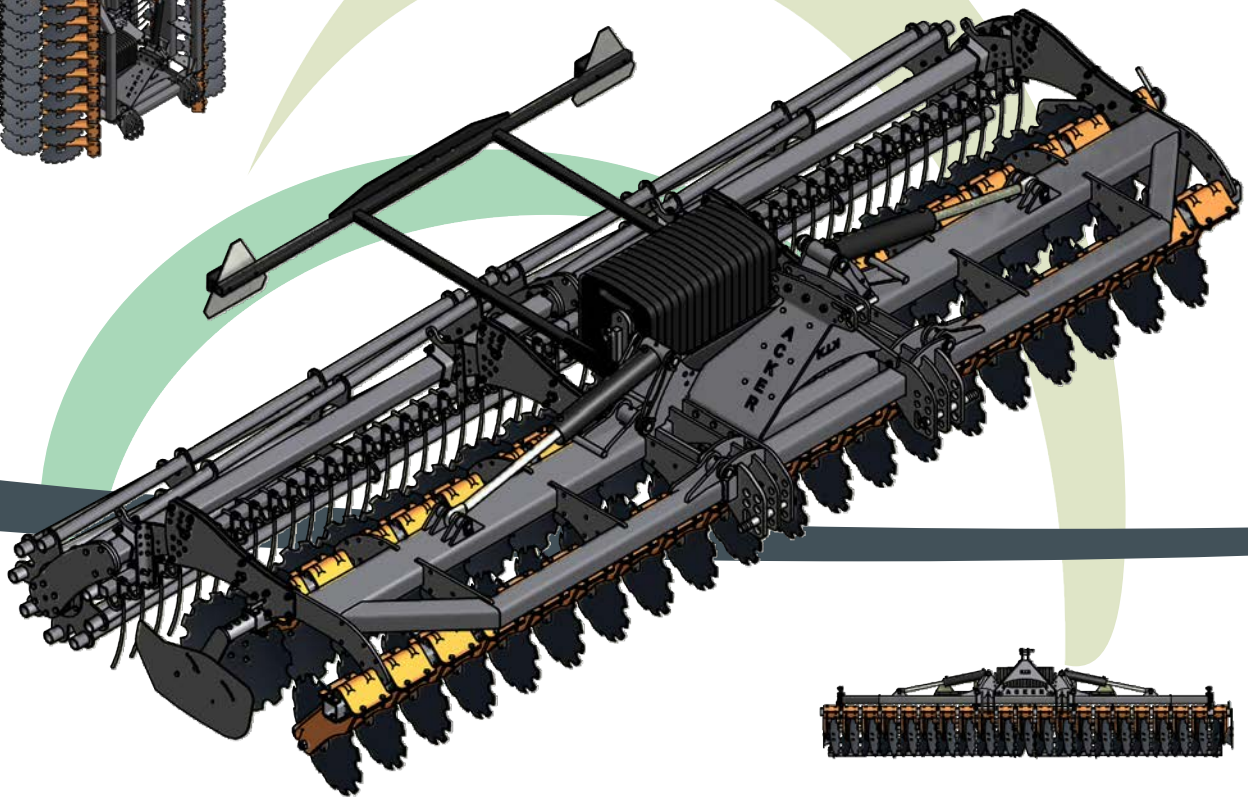
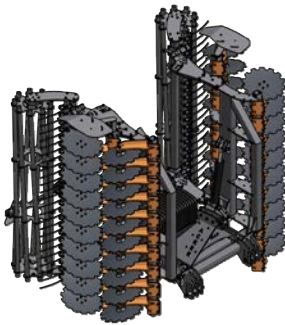

TYPE	TRACTOR HORSEPOWER	WORKING WIDTH	HYDRAULIC SHIFT	DEPTH OF WORK
	H.P.	cm		cm
KON-DISK AS 400	140-180	400	-/+	20
KON-DISK AS 450	150-240	450	+	20
KON-DISK AS 500	160-260	500	+	20
KON-DISK AS 550	180-280	550	+	20
KON-DISK AS 600	200-300	600	+	20

ADDITIONAL EQUIPMENT UPON REQUEST

- Base for the placement of counterweights
- Weight – counterweight 45 kg/item



Multi-disc KON-DISK AS

Folding-Hanging

Sindos Industrial Area 4-A7
 ZIP Code 57022, Thessaloniki
 T: +30 2310 79.79.84 -85
 T: +30 2310 79.99.88
 F: +30 2310 79.96.27
 info@acker.gr
 www.acker.gr

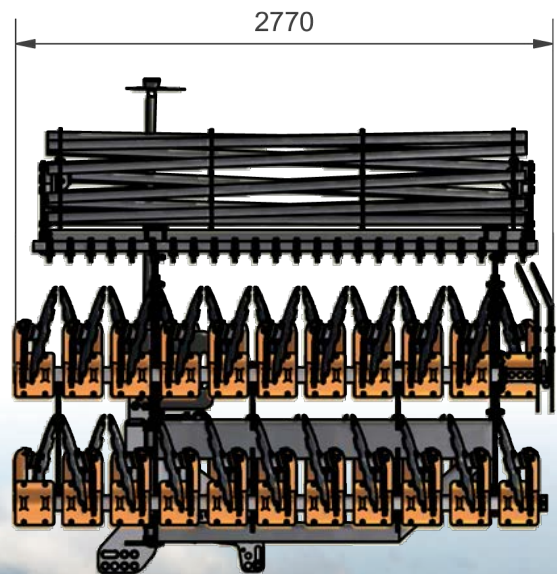
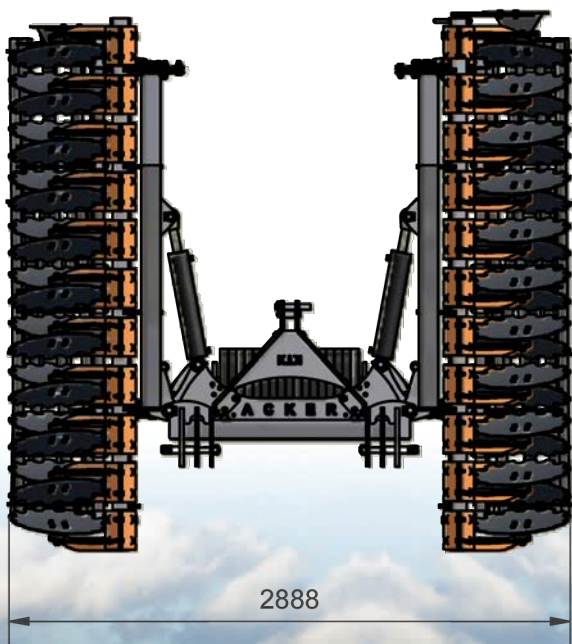
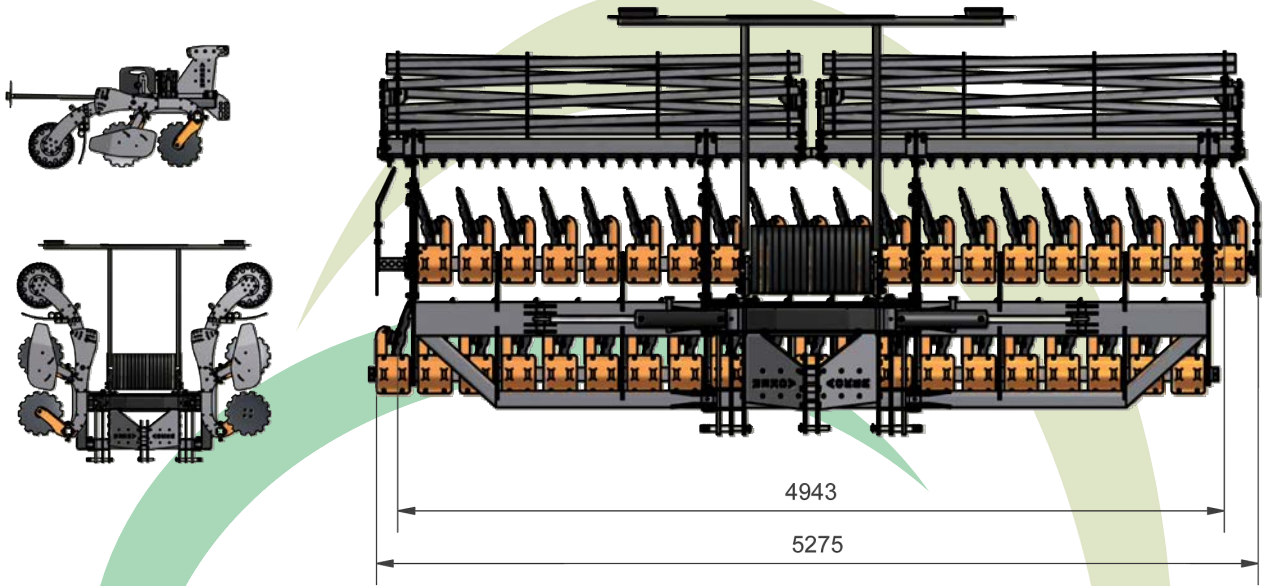

SPECIAL CONSTRUCTIONS (upon request)

Rotary Cultivator E-S (for strawberries)

Heavy-weighted agricultural cultivator for creating dikes for strawberry plants.



SPECIAL CONSTRUCTIONS (upon request)

Rotary Cultivator ES (for strawberries)

Heavy-weighted agricultural cultivator for creating dikes for strawberry plants.



SPECIAL CONSTRUCTIONS (upon request)

Rotary Cultivator ETK-S (for strawberries)

Heavy-weighted agricultural cultivator, suitable for strawberry cultivation.

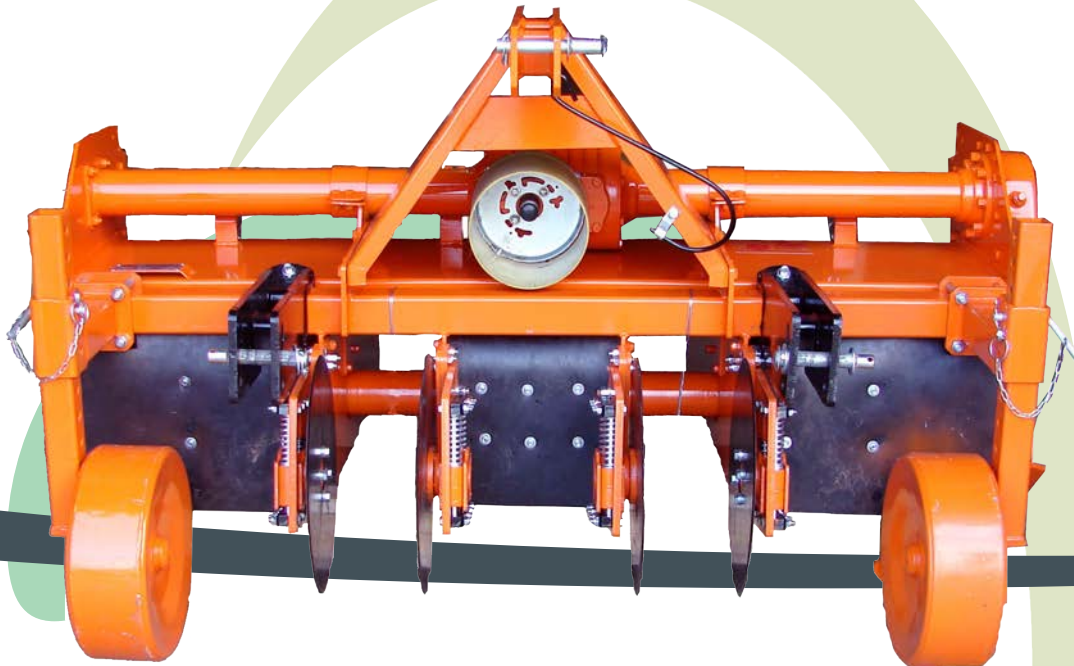

SPECIAL CONSTRUCTIONS (upon request)

Rotary Cultivator HY-S (for strawberries)

High-powered rotary cultivator, suitable for strawberry cultivation.



HY-S-610cm



HY-S-230cm



HY-S-380cm



SPECIAL CONSTRUCTIONS (upon request)

Rotary Cultivator KE-C (for carrots)

Heavy-weighted agricultural cultivator for creating dikes for carrot plants.



SPECIAL CONSTRUCTIONS (upon request)

Rotary Cultivator H2Y-C

Extremely heavy-weighted rotary cultivator for crumbling christmas tree trunks or similar heavy activities.



Rotary Cultivator H2Y-C

Sindos Industrial Area 4-A7
ZIP Code 57022, Thessaloniki
T: +30 2310 79.79.84 -85
T: +30 2310 79.99.88
F: +30 2310 79.96.27
info@acker.gr
www.acker.gr

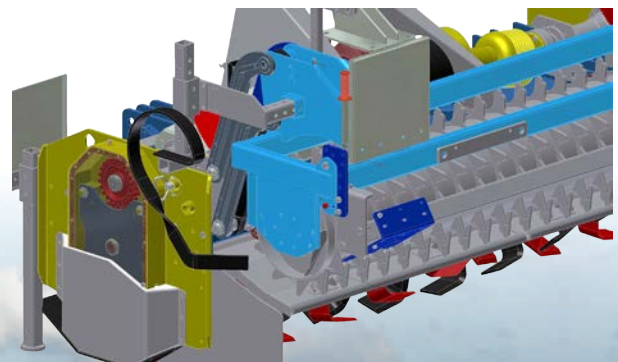
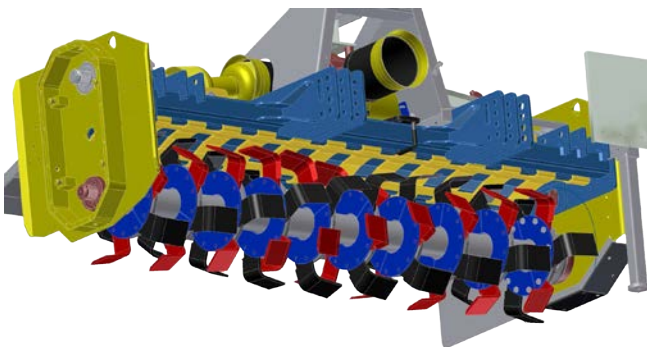
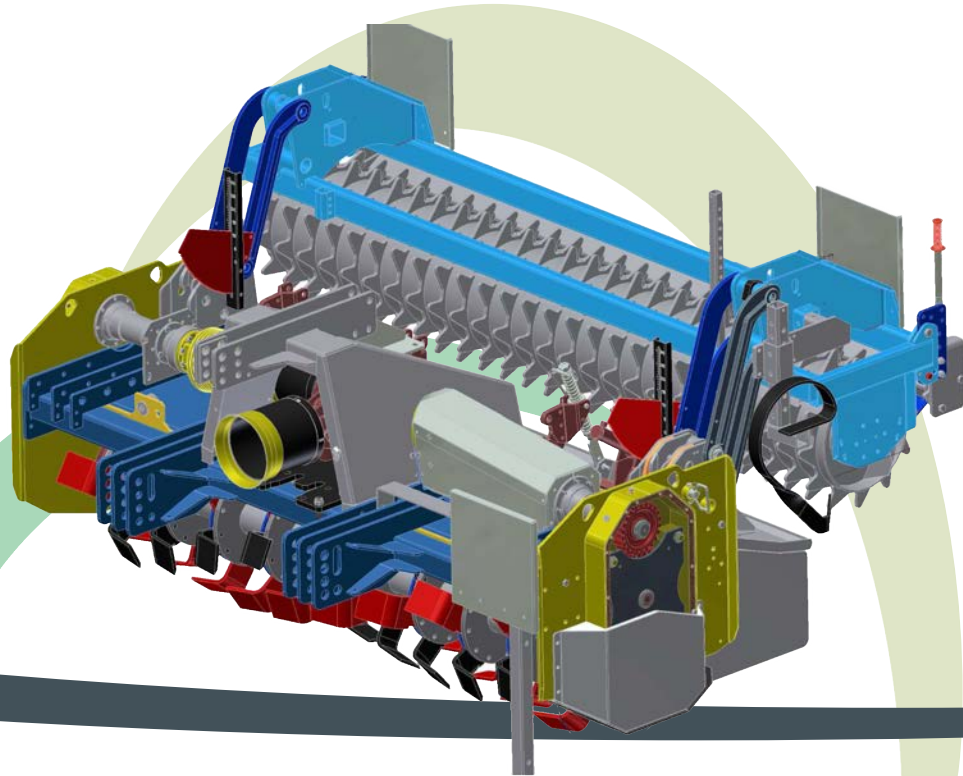

SPECIAL CONSTRUCTIONS (upon request)

Shredder KTS-SBY

Shredder with hydraulically movable side wheel for the elimination of weeds and branches between trees.



SPECIAL CONSTRUCTIONS (upon request)

Shredder KTS-SBK

Medium heavy-weighted rotary cultivator with type (SKN), hydraulically movable. Suitable for the elimination of weeds and branches between trees.



Rotary Cultivator SK-M

Medium heavy-weighted rotary cultivator with two wine hoes for cultivating between vineyards.





KONSTANTINIDIS

GROUP OF COMPANIES

Sindos Industrial Area 4-A7
ZIP Code 57022, Thessaloniki

T: 2310 79.79.84 - 85

T: 2310 79.99.88

F: 2310 79.96.27

info@acker.gr

www.acker.gr

